

2021 - 2022

BRUNSWICK

***CENTER
MAINTENANCE
PRODUCTS***

TRUSTED SINCE 1890

Brunswick[®]

FEATURED PRODUCTS

MAX – the new leader in lane machine technology, features Brunswick's Direct+ Conditioning system. Built to deliver superior performance, reliability, and consistency, MAX is very easy and intuitive to operate. MAX is designed to make lane care easy, reliable, and customized for the needs of bowling centers across the world.

The Phoenix LT4 is easy to operate and maintain. A perfect fit for smaller recreational centers.

ENVOY+ LANE MACHINE

See page 20



MAX LANE MACHINE*

See page 18



*MAX also available with black covers.



PHOENIX® LT4 LANE MACHINE

See page 19

HOOK ZONE LANE CLEANER

See page 12



FORMULA 45™ LANE CONDITIONER

See page 11



PINS

See page 4



PREMIUM RENTAL SHOES

See page 3

GREAT SHOT

Struggling to maintain a consistent, high-scoring lane condition that keeps your bowlers happy? Utilize Brunswick's complimentary "Great Shot" service. For more information visit our website at brunswickbowling.com.

HAPPIER BOWLERS = BIGGER REVENUE

TABLE OF CONTENTS

Bowling Center Supplies

House Balls	2
Ball Carts and Ball Ramp	3
Rental Shoes	3
Pins	4
Lane Monitor System	5
The Brunswick Advantage	6
Lane Conditioners	7
Lane Cleaners	12
Lane Cloth and Dusting Supplies	14
Maintenance Supplies	16

Lane Machines

MAX	18
Phoenix® LT4	19
Envoy+	20
Top Moving Lane Machine Parts	21

Resurfacing Products

Lane Finish	22
Finish Applicators	24
Bankshot™ Bumper Bowling	26
Foul Line Decal	26
Resurfacing Supplies	27
Replacement Lane Panels	28
Lane Parts	30

Order Forms

House Balls / Ball Carts and Ball Ramp / Rental Shoe / Pins	33
---	----

HOUSE BALLS

ORDER FORMS IN BACK OF CATALOG



MYBALL™ SYSTEM

R8-010059-000 - Fitting Ball and Display Stand

Make selecting a good-fitting house ball easier for your customers with the MyBall System from Brunswick. Our color-coded system and MyFit sizing ball allow customers to easily identify which ball will work best for them, improving bowler satisfaction.

- System includes the MyFit sizing ball with counter display
- Easy identification of hole size and weight. Speeds up the selection process – more time for bowling
- With the MyFit sizing ball, customers select from seven hole drilling sizes (XXS-XXL), then look for their preferred ball weight (6-15 pounds) with the selected hole size

HOUSE BALLS

60-105544-9XX - Undrilled

60-105544-XXX - Drilled

Liven up your center with Brunswick house balls. These bright, glow-in-the-dark bowling balls add color and excitement to any bowling environment. They are a great value and carry a two-year warranty; one year for six pound balls.

- New formulation Brunswick house balls radiate with light for the ultimate glow-in-the-dark bowling experience!
- Urethane balls available in 6 through 15 lbs
- Strong enough to withstand young or unskilled bowlers
- Available in seven drilling sizes as part of the MyBall System



6# - Lime Green Pearl Glow

7# - Fuchsia Pearl Glow

8# - Sky Blue Pearl Glow

9# - Violet Pearl Glow

10# - Orange Pearl Glow

11# - Purple Pearl Glow

12# - Red Pearl Glow

13# - Yellow Pearl Glow

14# - Kelly Green Pearl Glow

15# - Dark Blue Pearl Glow

BILLIARD HOUSE BALLS

60-105507-9XX - Undrilled

60-105507-XXX - Drilled

Brunswick billiards house balls, are ideal for boutiques, clubs, and themed centers. Stripes and Solids match standard billiards set. Weights from 6-15 pounds.



FLASH HOUSE BALLS

60-105986-9XX - Undrilled

60-105986-XXX - Drilled

Light up your center with the new Flash house balls from Brunswick! The Flash house balls are perfect for VIP areas, birthday parties, special events, or for making open bowling more fun and exciting.

- Made of 100% urethane, the Flash house balls feature LED lights embedded into the core of the ball.
- The bright and durable LED lights are initiated by a hard contact with any surface. They FLASH on and off as the ball travels down the lane.
- Available in 8, 10, 12, and 14 pounds. We offer a variety of drilling options that match up with the Brunswick My Ball fitting system.

See them in action! Go to brunswickbowling.com/products/house-balls



8 lb. - Lime Green Pearl



10 lb. - Pearlessence



12 lb. - Orange



14 lb. - Kelly Emerald Green Pearl

BALL CARTS, RAMP, AND RENTAL SHOES

ORDER FORMS IN BACK OF CATALOG



BALL CARTS

62-860311-XXX* - (Two Tier)

62-860312-XXX* - (Three Tier)

These durable and attractive ball carts enable you to easily transport house balls across the center as needed. Available in different colors. See color chart.



COLOR OPTIONS FOR BALL CARTS AND BALL RAMP

Color	Suffix*
Black	000
Silver	004
Green**	001
Yellow**	002
Blue**	003

**Special Order - 8 week lead time



BALL RAMP

62-860310-XXX*

The Ball Ramp enhances the bowling experience for younger bowlers, or those with special needs, making bowling more fun and bringing them back again and again. Available in different colors. See color chart.

REPLACEMENT PARTS

10-751601-000 - Leather Round Slab - Dia. 63.5 x 3

10-751602-000 - Leather Oblong Plate - 130 x 25 x 3

11-616528-000 - Knob - Star Grip - Plastic M8 x 25mm

11-695011-000 - Caster - ø 75mm x 98mm H. Light Duty

53-400496-000 - End Cap - Black



PREMIUM RENTAL SHOES

58-109114-XXX - Lace

58-109116-XXX - Hook-N-Loop

If only everything returned its investment as fast and as many times over as Brunswick Premium Rental Shoes. Featuring genuine full-grain leather uppers and soles, foam-padded sock liners, channel stitching, and rubber heels, these shoes are built to last game after game.

- Lace or Hook-n-loop closures
- Glow laces
- Reinforced stitching
- Premium, full-grain leather upper
- Leather sole with channel stitching



HYBRID RENTAL SHOES

58-109305-XXX - Adult Lace

58-109306-XXX - Adult Hook-N-Loop

58-109304-XXX - Youth Hook-N-Loop

- Contemporary look
- Full grain leather soles with recessed stitching
- Double stitched synthetic uppers
- Padded insoles and air grommets
- Lace pairs come with extra laces



YOUTH RENTAL SHOES

58-109115-XXX

- Full-grain leather uppers and lining
- Leather sole with channel stitching
- Hook-n-loop closure
- Eyelets on inside of arch for airflow
- Colors coordinate with Premium rental shoes.



VALUE SPORT SHOES

58-109302-XXX Youth Lace

(Sizes 3.5-7 - EU sizes 24-32
Half sizes beginning at size 1)

58-109303-XXX - Adult Lace

(Sizes Men 4-16, Women 5.5-12.5, EU 36-50)

- Synthetic upper for long life
- Leather sole and rubber heel pad
- Enamel-covered eyelets for added strength
- Eyelets on inside of arch for airflow

PINS

ORDER FORMS IN BACK OF CATALOG



SCORE KING® PINS

63-861179-167 - Crowns

63-861180-167 - Crowns – Glow Graphics

63-861181-167 - Stripes

63-861182-167 - Stripes – Glow Graphics

MAX PINS

63-861167-167 - Crowns

63-861165-167 - Crowns – Glow Graphics

63-861168-167 - Stripes

63-861166-167 - Stripes – Glow Graphics

Brunswick Max and Score King Pins give bowlers the high-scoring action they want and the features you need for maximum durability.

- Multilayer topcoat system keeps pins white and glowing brightly
- Surlyn cover allows for a larger wood core to ensure maximum strength
- Made of the finest northern hard rock maple for maximum durability and pin action
- Score King pins feature a heavy-duty, locked-in black nylon base that looks great. Max pins have a neutral locked-in base that stays in place
- Coated Surlyn cover cleans easily and stays whiter longer
- Score King and Max pins are USBC® approved
- All Brunswick pins are made in the USA
- Choose stripes or crown neck graphics
- Available in sets of ten or individually



MAX COLORED PINS

63-861137-167 - Green

63-861139-167 - Orange

63-861138-167 - Yellow

63-861161-167 - Magenta

Let the good times roll with these fun and colorful Max pins. Change out the front pin or the whole set for a new twist on the game. Available in four vibrant, solid colors. Available in single-color sets of ten or individually.



TROPHY PINS

63-861157-167 - Sets

63-861157-000 - Singles

Perfect for special occasions to help your bowlers remember a significant score or event, our Trophy Pin is made of maple wood covered in a clear topcoat. It can be used as a signature pin for birthday parties or other special events. Available in sets of ten or individually.



HAPPY BIRTHDAY PINS

62-861092-167 - Happy Birthday

Help your bowlers celebrate their birthdays with this special-occasion pin featuring the crown graphic as well as a "Happy Birthday" message. The Happy Birthday Pin is a Surlyn-coated maple wood pin that can be used for signatures, too. Available in sets of ten or individually.



STRING PINS (SET OF 10)

63-861169-167 - Max Graphic Glow Crown

63-861170-167 - Max Red Crown

STRING PINS - COLORS (SET OF 10)

63-861171-167 - Magenta

63-861172-167 - Green

63-861173-167 - Yellow

63-861174-167 - Orange

STRING PIN (SINGLE)

63-861169-000 - Max Graphic Glow Crown

63-861170-000 - Max Red Crown

STRING PIN - COLORS (SINGLE)

63-861171-000 - Magenta

63-861172-000 - Green

63-861173-000 - Yellow

63-861174-000 - Orange



DUCKPINS (SET OF 10)

63-861001-000 - American Style



5" DUCKPIN BALLS (6 PER PKG)

55-860066-001 - Black Speckled

55-860066-002 - Blue Speckled

55-860066-003 - Brown Speckled

55-860066-004 - Cranberry Speckled

55-860066-005 - Green Speckled

55-860066-006 - Orange Speckled

55-860066-007 - Red Speckled



UNIVERSAL PIN CLEANER

63-860354-005

Keep pins looking bright and new with this advanced performance cleaner.

- Removes the grime and dirt from pins
- Bgreen product – formulated to be readily biodegradable and environmentally friendly
- Can be used with both hand and machine cleaning systems
- "Universal" because it also makes a great general purpose bowling equipment cleaner

LANE MONITOR SYSTEM

DISCONTINUED PRODUCT LINE
INVENTORY REMAINS FOR SALE, FIRST COME FIRST SERVE

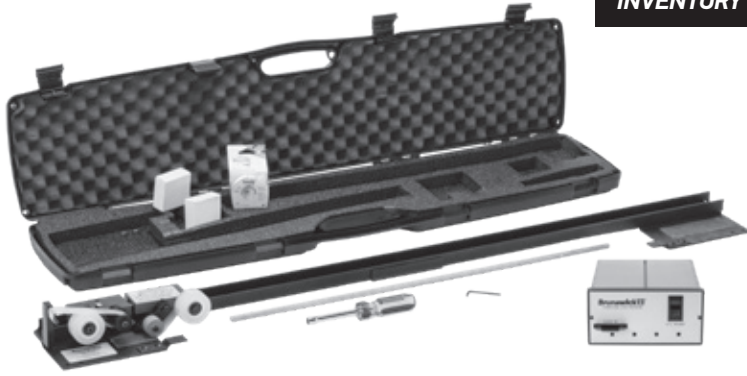

COMPUTER LANE MONITOR SYSTEM™

61-860226-600 - (110 V)

61-860226-620 - (220 V)

Computer Lane Monitor System reduces maintenance time and human error. Includes:

61-100057-000 - (White Label Tape)

11-900070-000 - (UV Pick-Up Tape)

61-860162-000 - (Calibration Kit)

61-860155-000 - (Lane Recorder)

61-860225-600 - (Computer Lane Reader, 110V)

61-860225-620 - (Computer Lane Reader, 220V)

- System includes all components of Computer Lane Monitor Optical Reader, Lane Monitor Recorder, Calibration Kit, UV Pick-Up Tape and White Marking Tape
- Based on the computerized Optical Reader, this system takes the guesswork out of reading tapes and provides immediate, accurate feedback
- Windows® software provides more detailed analysis including 3-D graphics (IBM® compatibility required)
- Measure newly conditioned lanes, as well as changes in lane conditions, such as oil depletion and carry-down
- Keep bowlers satisfied by ensuring that lane conditions are the same from lane to lane and week to week
- Verify lanes are in compliance with USBC® and World Bowling conditioning rules
- The lane monitor system requires use of a lane conditioner containing USBC specified UV additive



LANE MONITOR RECORDER

61-860155-000

The original Lane Monitor Recorder is still the best.

- Two sliding tape carriages in an aluminum track are placed on the lane from gutter to gutter
- One carriage applies the transparent tape to the lane surface to absorb the dressing
- The second carriage lifts the dressing tape and laminates to a second tape, locking the dressing between the two, creating a permanent, accurate sample of the conditioner pattern
- Comes complete with all recorder components, recorder tape, label tape, assembly tool and instructions in a sturdy case

WHITE MARKING TAPE

61-100057-000

UV PICK-UP TAPE

11-900070-000

TAPE HUB

61-100055-003



RUBBER WHEEL ASSEMBLY

61-100055-004

FOOT PAD SMALL

61-100055-016

FOOT PAD LARGE

61-100055-018



COMPUTER LANE MONITOR OPTICAL READER

61-860225-600 - (110 V)

61-860225-620 - (220 V)

An industry standard since 1988, the Brunswick Lane Monitor provides the ultimate in accuracy and reliability for measuring and graphing lane conditioner volume and distribution.

- Higher resolution for improved accuracy
- Increased range accommodates higher conditioner volumes
- Addition of USB port provides compatibility with new PCs
- User-friendly software
- Holds higher graph scales
- High capacity tapes are conveniently read from end to end

COMPUTER LANE MONITOR SOFTWARE

61-860273-400 - CD V1-01

61-860273-401 - CD V2.00



RUBBER ROLLER

61-100261-000



CALIBRATION KIT

61-860162-000

- Package of three strips
- It is recommended to replace calibration strips after one year



UV BULB

61-100060-000

ROLL PIN (1/8" X 1/2")

11-345154-000

THE BRUNSWICK ADVANTAGE



Brunswick has been a pioneer in lane maintenance products. Brunswick began manufacturing the B90 lane machine for bowling centers in the 1960s. Over the last fifty-plus years, Brunswick has continuously invested in the development of 3Cs products. The knowledge and products of Perry-Austen and DBA, early leaders in lane maintenance, have been incorporated into Brunswick's lane maintenance offering. Knowing more about our commitment can help you better manage your center lane maintenance needs.

DEDICATED R&D TEAM

In support of Brunswick's commitment to lane maintenance research and development, Brunswick has a committed 3Cs R&D team. This multi-faceted group consists of project managers, chemists, researchers, purchasing agents and marketing professionals focused on developing innovative new products that advance the science of lane maintenance.

A FOCUS ON SCIENCE AND TECHNOLOGY – THROBOT™

ThroBot, Brunswick's state-of-the-art ball-throwing robot, was designed and fabricated in the late 1990s for bowling ball development. Computer controlled, it combines hydraulics, air pressure and electronics to power a mechanical arm that delivers bowling balls predictably down the lane. ThroBot can simulate nearly any bowler's style including speed, rev rate, axis tilt, and rotation.

In the early 2000s, Brunswick engineers began exploring different ways to objectively measure lane conditioner performance. Through these studies, ThroBot data was used to develop a set of equations which correlate ball position to lane oil pattern transition, providing an objective measure of conditioner performance. In the late 2000s, the equations were updated to separate performance within and beyond the oil pattern.

Brunswick continues to use ThroBot to analyze and develop state-of-the-art lane conditioners and even cleaners. After multiple ThroBot tests, engineers are able to measure how different product formulations perform relative to the same ball, conditioner pattern, and lane surface. With this data in hand, Brunswick chemists can create new additive packages with specific characteristics.

CONTINUING COMMITMENT

ThroBot is an example of Brunswick's commitment to use scientific research to measure and enhance performance bowling products. Brunswick is the only supplies manufacturer with this technology and research methodology. Brunswick's R&D in 3Cs is unrivaled, and a competitive advantage for your bowling center.

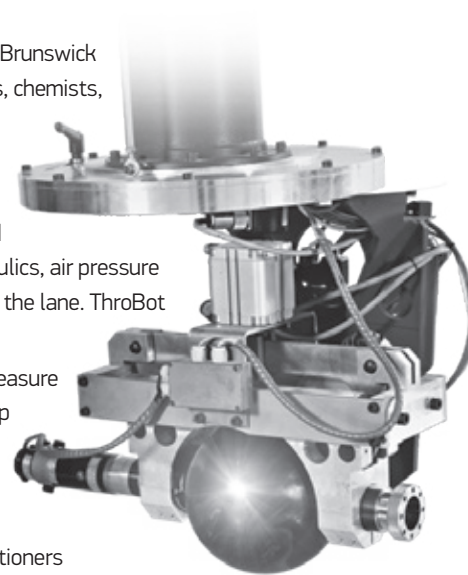

LANE CONDITIONERS

BRUNSWICK LANE CONDITIONERS

Choosing the correct lane conditioner is paramount. Choosing the correct conditioner allows for higher scores, how long the pattern holds up and may aid in pinsetter maintenance. Conditioners are the most expensive part of daily lane care, let Brunswick help you make the most of this expense.

WHAT LANE CONDITIONER DOES

- Protects lanes surface against the forces of bowling balls in the impact area of the lane and reduces the friction applied to the lane surface as the ball travels down the lane – helping the proprietor get the most life from their surface investment.
- When the correct conditioner is selected for the surface, accompanied with the correct lane pattern, conditioners create higher scores.

LANE MACHINE TYPES

- Wick machines – conditioner is drawn up from a reservoir by wicking-action then applied to the lane through a transfer system of brushes/rollers (e.g., Phoenix Lite).
- Pump machines – conditioner is released onto a transfer system which ultimately spreads it over the lane (e.g., Kegel Sanction technology machines).
- Direct + lane machines - conditioners are sprayed directly onto the lane surface (e.g., Authority 22, Envoy or Max).

KEY PHYSICAL CHARACTERISTICS OF BRUNSWICK LANE CONDITIONERS

Lane Conditioner	Viscosity in cPs @ 70° F	Surface Tension	Predictability		Lubricity
			Oil	Backend	
Formula 45™	45.0	25.0	7.50	7.90	Low
Logic™	43.0	25.0	6.84	6.50	Low
Control®	37.0	24.5	6.03	5.89	Med
Connect®	33.0	24.5	5.54	5.50	Med-Low
Absolute Control®	22.0	24.0	9.15	2.38	Med-High

VISCOSITY – thickness: “the resistance to flow of a liquid or semi-liquid”

- The greater the viscosity, the thicker the conditioner
- Viscosity closely reflects a conditioner’s ability to reduce friction, but it is not specifically a measure of this (see “Lubricity” below)
- Conditioners of different viscosity work better (or worse) for different centers with different types of lanes using different lane machines

SURFACE TENSION – Surface tension is the resistance of a fluid to deform or break under an external force. Surface energy refers to the sum of intermolecular forces that are on the surface of the lane, which influences how well an oil will lay out on, and interact with, the lane surface.

- Conditioners with lower levels of surface tension tend to lay better on the lanes, resist carry down and create better ball reaction
- Conditioners with higher levels of surface tension tend to “bead up,” attaching themselves to balls more easily and increasing oil carry-down

OIL PREDICTABILITY – an exclusive Brunswick measurement of the stability within the oil pattern: how long an oil pattern holds up before it begins to deplete and change the lane’s performance

- Measured by testing with ThroBot™
- More durable/lasting conditioners get higher oil predictability values, while conditioners that transition sooner will have lower values

BACK-END PREDICTABILITY – an exclusive Brunswick measurement of the stability of the entry angle on the back-end, as a result of carry-down beyond the oil pattern

- Also measured by testing with ThroBot
- Measures carry-down of conditioner onto the back-end of a lane, where the conditioner is not initially applied
- Oil carry-down reduces a ball’s ability to see friction and hook over the final section of the lane
- Conditioners with higher back-end predictability values have less carry down, preserving consistent back-end ball reaction

LUBRICITY – slipperiness: “the capacity of a solution to reduce friction”

- Affects how the ball loses speed in the conditioner pattern, which in turn determines how the ball responds to friction
- Manufacturers make conditioners with different lubricities to provide different performance characteristics and work well with different types of lane surfaces and lane machines
- Higher lubricity conditioners (more slick) are better for use on fast-response (“hooking” or “worn”) lane surfaces since they provide a slower response time. Balls can be more affected by carry down with this type of conditioner and may require the pattern volume to be lower.
- Lower lubricity (less slippery) conditioners are excellent for use on slow-response (harder, less “hooking”) lane surfaces since they provide a faster response time. Low lubricity conditioners may require the pattern volume to be higher.

LANE CONDITIONERS

LANE CONDITIONING TIPS

I HAVE TOO MUCH CARRY-DOWN

Complete “clean only” run to ensure you are cleaning effectively. If cleaning is achieved, then look at your pattern. Decrease the distance of the applied oil in the center of the lane leaving the pattern distance the same. This adjustment increases the buff distance and reduces the oil thickness at the end of the pattern. Check to see if lanes are cleaned completely.

I DON'T HAVE ENOUGH HOLD

Hold is created by the length and amount of oil in the “mid-lane” (20-32 ft.). This is done by applying oil in the mid-lane on the reverse pass of most lane machines. Lengthening the reverse application distance creates hold oil which allows the ball to more consistently guide to the breakpoint. With Brunswick's Direct+ Conditioning this can be easily accomplished by adding oil to the required boards in zones that affect the mid lane during the forward run.

MY BACK ENDS ARE TOO STRONG

Verify dilution ratio of lane cleaner is correct, then look at your pattern. Lengthen the pattern to “tone” down the ball reaction. Make sure that the conditioner application distance does not change, only the total pattern distance.

THE HEADS HOOK

Two things cause the heads to hook. 1. Not enough oil applied to the head area. 2. The physical condition of the heads. To increase the volume of oil in the heads, slow the machine down on the reverse pass. With Brunswick's Direct+ oil system, during the forward run you can increase the units of oil by board in the head zone(s) to resolve this problem.

I HAVE NO SWING AREA

Complete “clean only” run to ensure you are cleaning effectively. If cleaning is achieved, then look at your pattern. A lack of swing area can be caused by two things: 1. too much oil applied to the outside boards or 2. “crowned” lane topography. Reduce the amount of oil on the outside boards if there is too much. If topography is the problem, contact your professional lane resurfer. Check cleaning of the outside of the lane. Adjust cleaner dilution.

THE MID-LANE BALL TRACK HOOKS TOO MUCH

The mid-lane ball track can hook if there is not enough oil or if there is too much oil. This can be determined by looking at the pattern settings along with Computer Lane Monitor graphs.

For help with your lane conditions, call 1-800-YES-BOWL, or contact your Brunswick Aftermarket Product Specialist. Contact info at brunswickbowling.com/contact/aftermarket-product-specialists.

BENEFITS OF BRUNSWICK PERFORMANCE CONDITIONERS

- **PERFORMANCE** – products produce desired ball motion and more consistent scoring
- **DURABILITY** – products retain their original performance for longer between applications
- **STABILITY** – does not separate, no need to “shake well before using.”
- **CONSISTENCY** – composition of ingredients and consistency is the same from batch to batch.
- **VALUE** – products deliver high performance per dollar
- **SUPPORT** – products are from Brunswick, renowned for customer care and follow-up service

INFORMATION YOU NEED TO CHOOSE THE RIGHT BRUNSWICK CONDITIONER

- Lane machine type and condition
- Conditioner currently in use
- Lane surface and condition
- Lineage, and # of leagues vs. open play?

Since the shot is a combination of the right conditioner and pattern, you will also need to know the patterns currently being used, how they perform, and what you consider an improvement to the shot.

HOW TO CHOOSE THE RIGHT BRUNSWICK REPLACEMENT CONDITIONER

There are two basic ways to do this. You can either:

- Identify the Brunswick conditioner that is most comparable to the brand now being used. Use the chart on the next page – Suggested Brunswick Replacements for Other Brand Lane Conditioners - to find the nearest Brunswick equivalent.
- Find the Brunswick conditioner that is best suited to the center's lane machine, lane surface and determine if your center caters more to leagues or recreational play. The Conditioner charts for different lane machine types that follow take these factors into account and identify which Brunswick conditioners will work best.

LANE CONDITIONERS

Brunswick has spent much time in Research and Development to design products to better fit the customers needs. Lane surfaces, machine types, and environmental factors have been taken into consideration when developing the most complete line of conditioners in the market today.

BRUNSWICK REPLACEMENTS FOR OTHER BRAND LANE CONDITIONERS

If you are interested in trying a similar product to your current conditioner, consider the Brunswick conditioner listed in the second column.

Competitive Lane Conditioner	Brunswick Recommended Lane Conditioner	Competitive Lane Conditioner	Brunswick Recommended Lane Conditioner
Kegel Offense HV	Connect	Lane Concepts Lubricity S	Absolute Control/Control
Kegel Navigate	Control	Lane Concepts Lubricity W	Absolute Control/Control
Kegel Infinity	Logic	Lane Concepts C1-Pro (19)	Absolute Control
Kegel Prodigy	Absolute Control	Lane Concepts C1-Pro (26)	Connect
Kegel Crossfire	Absolute Control	Lane Concepts Break-Point	Connect
Kegel Defense S	Logic	Polychem Signature Edition 28	Connect
Kegel Ice	Absolute Control	Polychem CEO 33	Connect
Kegel Fire	Connect	Polychem CEO 42	Logic/Formula 45
Kegel Curve	Logic	Polychem CEO 65	Logic/Formula 45
QAMF Utopia	Formula 45	Polychem Shotmaker 9544	Absolute Control
QAMF Reactor LL	Absolute Control	Polychem Shotmaker 9557	Absolute Control
QAMF Reactor ML	Absolute Control	Polychem Shotmaker 9584S	Absolute Control
QAMF Reactor HL	Connect	Polychem 509	Absolute Control
QAMF Visflo 12.7	Absolute Control	Polychem 9512	Absolute Control
QAMF Visflo 19.5	Absolute Control	Polychem 9526 ULTIMIT	Absolute Control/Control
QAMF Visflo 32.5	Connect	NeoTac Neo 1	Absolute Control/Control
QAMF Visflo 39	Control	NeoTac Black Gold Texas Tea	Absolute Control/Control
QAMF Visflo 48.5	Logic/Formula 45	NeoTac Black Gold 50/50	Absolute Control/Control
Lane Concepts SynPro 40	Logic/Formula 45		

When two or more conditioners are recommended, both are recommended equally.

CONDITIONERS FOR USE IN PUMP AND INJECTOR-TYPE MACHINES

Lane Type	Condition Of Lanes	Recreation Center	League Center
Wood with Barricade/Guardian	All	Absolute Control®	Absolute Control
Wood with Water-base Finish	All	Absolute Control	Absolute Control, Control®
Wood with Moisture Cure, Urethane Finish or 100% Solids, Epoxy Finish	All	Absolute Control	Control
Wood with Lane Shield	All	Control	Control
AMF HPL 9000, 1/2" DBA IQ, 7/16" Anvilane	All	Connect®, Control	Connect, Control
Brunswick Pro Lane™ (textured approach), 3/8" Anvilane, AMF SPL, Murrey Pathfinder II, System 300, Mendes	All	Connect	Connect, Control, Formula 45™, Logic™
Brunswick Pro Lane (non-textured approach)	Good-Excellent	Control, Formula 45, Logic	Connect, Control, Formula 45, Logic
Brunswick Pro Lane (non-textured approach)	Fair-Poor	Connect, Control	Connect, Control, Formula 45, Logic

CONDITIONERS FOR USE IN WICK-TYPE MACHINES

Lane Type	Condition Of Lanes	Recreation Center	League Center
All	All	Absolute Control	Absolute Control

LANE CONDITIONERS

PERFORMANCE CONDITIONERS



LOGIC™ LANE CONDITIONER

62-860162-005 - (5 Gallons)

Logic Lane Conditioner blends top-grade oils with an enhanced additive package. Logic is a low lubricity conditioner with excellent durability that is optimized for low friction surfaces.

- 100% solids, 43.0 viscosity
- 25.0 surface tension
- Resistant to break down
- Consistent performance

Easily removed by all Brunswick lane cleaners.

ThroBot™ approved.

USBC approved.



CONNECT® LANE CONDITIONER

62-860160-005 - (5 Gallons)

Connect Lane Conditioner blends top-grade oils with an enhanced additive package. Connect is a medium-low lubricity conditioner with excellent durability that is optimized for medium to low friction surfaces.

- 100% solids, 33.0 viscosity
- 24.5 surface tension
- Resistant to break down
- Consistent performance

Easily removed by all Brunswick lane cleaners.

ThroBot approved.

USBC approved.

VERSATILE CONDITIONER



CONTROL® LANE CONDITIONER

62-860046-005 - (5 Gallons)

Control Lane Conditioner offers long-lasting patterns, reduced carry-down, and consistent ball reaction. Control is a medium lubricity conditioner with great durability that is optimized for medium to low friction surfaces, but can be used with all surface types.

- 37.0 viscosity
- 24.5 surface tension
- Resists breakdown
- Consistent performance

Easily removed by all Brunswick lane cleaners.

ThroBot™ approved.

USBC approved.

LANE CONDITIONERS

WICKING CONDITIONER



ABSOLUTE CONTROL® LANE CONDITIONER

62-860143-005 - (5 Gallons)

Absolute Control Lane Conditioner is a medium-high lubricity conditioner with great durability that is optimized for centers that have wood lanes, high friction surfaces, or wick/pad style machines.

- 22.0 viscosity
- 24.0 surface tension
- Resists breakdown
- Consistent performance

Easily removed by all Brunswick lane cleaners.

ThroBot approved.

USBC approved.

VALUE CONDITIONER



FORMULA 45™ LANE CONDITIONER

62-860161-004 - (4 Gallons)

62-860161-001 - (1 Gallon)

Formula 45 uses a special blend of oils with an enhanced additive package to create a low lubricity conditioner that gives predictable and strong ball reaction. It has been optimized for low friction, synthetic lane surfaces. It can be used with Brunswick Direct+ conditioning system and Sanction technology machines.

- 45.0 viscosity
- 25.0 surface tension
- Resists breakdown
- Not recommended for wick or pad machines

Easily removed by all Brunswick lane cleaners.

ThroBot approved.

USBC approved.

LANE CLEANERS

Today there are only three effective ways to remove conditioner from the lane, these are surfactant driven cleaners, pH driven cleaners, and solvent driven cleaners. Brunswick is the only manufacturer offering all three forms of cleaners.

- All cleaners are concentrates, since all cleaners are diluted with water before use
- Dilution ratios range from as little as 4:1 to as high as 50:1

PRO TIP: FINDING THE IDEAL RATIO

Lane cleaner is the second largest cost in daily lane care and changing cleaner or cleaner ratios during a season is less threatening than changing a conditioner. Understanding what each type of cleaner does to a surface and how dilution ratios effect the cleaning will complete a loop in overall lane conditions. Remember it is a combination process, cleaning and conditioning is a 50/50 relationship. If lanes are not cleaned and conditioner is applied the pattern will change continually. Getting the lane clean is paramount in daily lane care.

MAKING THE CLEANING THE MOST COST EFFECTIVE

All dilution ratios suggested by the manufacturers are designed to mix a cleaner at its maximum strength without causing negative effects. This gives each center the opportunity to custom tailor dilution ratios to fit individual center needs and improve the amount of cleaner needed each day.

- Centers can find the ideal dilution ratio by progressively adding more water to the solution until lane cleaning becomes ineffective, then returning to an acceptable (less diluted) solution for daily lane care

THINGS TO CONSIDER WHEN CREATING THE PERFECT DILUTION RATIO FOR YOU

- Frequency of lane maintenance
- Climate (temperature)
- Type of lane machine used

SOLVENT BASED CLEANER



HOOK ZONE LANE CLEANER

62-860251-005 - (2x2.5 Gallons)

Hook Zone Lane Cleaner has paved the way for a new class of cleaners for Brunswick. Utilizing a highly effective, 100% liquid formula, this fast-acting solvent driven cleaner leaches the lane surface, and leaves a squeaky-clean lane. It can be paired with all lane conditioners on the market today.

- Premium performance
- Purple color to aid in mixing ratio verification
- User friendly, near neutral pH
- Can be readily mixed with Isopropyl Alcohol (IPA) to aid in cleaning on humid days
- Recommended starting dilution with filtered water:
4:1 - Concentrate - 62-860251-005

Water based, non-hazardous cleaner.
For vacuum lane cleaning only.

HOOK ZONE - SUPER CONCENTRATED LANE CLEANER

62-860251-025 - (1x2.5 Gallon Super Concentrated)

- Recommended starting dilution with filtered water:
16:1 - Super Concentrate - 62-860251-025



SURFACTANT BASED CLEANER



MAX10 LANE CLEANER

62-860239-025 - (2.5 Gallons)

MAX10 Lane Cleaner has been formulated as a heavy-duty, surfactant driven, concentrated cleaner. It has been designed to work fast and be highly effective in removing newer lane conditioners that contain high viscosity oils and performance additive packages.

- Premium performance
- Fresh scent
- Recommended starting dilution with filtered water: 10:1
- Save on freight, makes 10% more product than 5 gallons of 4:1 cleaners
- Promotes neutral, consistent back-end reaction

Water based, non-hazardous cleaner.

Bgreen cleaner.

For vacuum lane cleaning only.

pH BASED CLEANER



INVINCIBLE® LANE CLEANER

62-860055-005 - (5 Gallons)

62-860055-030 - (30 Gallons)

Invincible Lane Cleaner is a high pH cleaner that is designed to tackle the cleaning requirements for the widest application of centers.

- Guaranteed Performance
- Recommended starting dilution with filtered water: 4:1
- Promotes consistent back-end reaction

Water based, non-hazardous cleaner.

Bgreen cleaner.

For vacuum lane cleaning only.

HYBRID CLEANER



JUDGE® LANE CLEANER

62-860066-005 - (5 Gallons)

Judge Lane Cleaner has been formulated with a specific combination of additives (pH & solvent), with the goal of effectively removing difficult to clean lane conditioners.

- Optimum performance
- Fresh scent
- Recommended starting dilution with filtered water: 4:1
- Promotes stronger back-end reaction

Water based, non-hazardous cleaner.

Bgreen cleaner.

For vacuum lane cleaning only.

LANE CLOTH AND DUSTING SUPPLIES

Lane cloth is the least costly item in daily lane care and is an effortless transition. There are different types of lane cloth for different types of lane machines. Choose the Brunswick lane cloth that fits your machine and allow Brunswick to save you money on your daily lane care.



BEST FOR KEGEL® MACHINES

8460QC LANE CLEANING CLOTH

61-860290-000 - (4 Rolls/carton)

8460QC uses the same proven heavy-duty material found in the 8460XL blue cloth but features a quick-change plastic core. This new design will save you time and scrub your lanes clean.

- Saves time
- Easy to use
- Eliminates hassle
- Use with Kegel® wick/pad and pump lane machines 2004 and newer
- 20 yards per roll



8460XL LANE CLEANING CLOTH

61-860250-000 - (4 Rolls/carton)

8460XL virtually "scrubs" cleaning solution onto the lane with its special fiber cloth.

- Heavyweight cleaning cloth
- Use with Kegel wick/pad and pump lane machines pre 2004
- 18 1/3 yards per roll



BEST FOR BRUNSWICK MAX, ENVOY, AND AUTHORITY22 MACHINES

ENVOY®/AUTHORITY22® DUSTER CLOTH

62-860207-000 - (4 Rolls/carton)

Envoy/Authority22 Duster Cloth cleans the lane before the cleaner is applied. The process uses less cloth and helps the cleaner work directly on the conditioner, not the surface dirt.

- Water-resistant core
- Special fiber maximizes scrubbing action
- Absorbs dirt and cleaner fast
- For use in Brunswick injector lane machines
- 20 yards per roll



BEST FOR BRUNSWICK LANE DUSTER, ALL CENTURY MACHINES, PA CHAMPION, CENTURY HOT DUSTER, DBA STRIP N' DUST, DBA LANE WALKER, DBA EXCEL MACHINES





GOLD EDGE LANE CLEANING CLOTH

61-860252-000 - (4 Rolls/carton)

Gold Edge Cloth is composed of a special mixture of fibers to maximize "scrubbing action" and edge out the competition.

- Quick-absorbing design for fast and complete cleaner pickup
- Specially designed scrubbing weave
- Use with wick/pad and pump lane machines
- 20 yards per roll

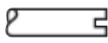
LANE CLOTH AND DUSTER COMPARISON CHART

Lane Machine or Duster Type	Brunswick	AMF	Rolls Core/Dowel	Yards PER Carton	Cloth Per Roll	Overall Width	Width
Kegel Machines 2004 and Newer	61-860290-000	N/A	Plastic	4	20	43"	44-3/4"
Kegel Machines Pre 2004	61-860250-000	294008460	 CORE	4	18-1/3	43"	44-3/4"
Envoy/Authority22	62-860207-000	N/A		4	20	43"	44-3/4"
Gold Edge Lane Cleaning Cloth	61-860252-000	N/A	 CORE	4	20	43"	44-3/4"
Brunswick, DBA, Perry-Austen Lane Maid DBA Aluminum Duster DBA Lane Runner	61-860168-000	294008430	 DOWEL 7/8" Diameter	3	33-1/3	43"	44-3/8"
Brunswick Lane Duster All Century Machines PA Champion Century Hot Duster DBA Strip n' Dust DBA Lane Walker DBA Excel	52-860078-000	294008443	 CORE	4	25	43"	44-3/4"

LANE CLOTH AND DUSTING SUPPLIES



BEST FOR HAND DUSTERS

RED EDGE® ** LINO-DUSTER CLOTH

61-860168-000 - (3 Rolls per carton)

52-860078-000 - (4 Rolls per carton)

Red Edge Lino-Duster Cloth contains strong, long fibers that trap and hold dirt improving cleaning performance.

- Removes dirt, while leaving conditioner pattern undisturbed
- Available in two sizes to fit many lane dusters
- 100 yards per box

**See Chart on Page 10.



BRUNSWICK LANE MAID

61-860158-001

Brunswick's unique design provides the ideal way to get the dust without disturbing the lane condition.

- Aluminum support bar applies even pressure to foam pad and duster cloth for a complete cleaning, regardless of lane conditions
- Cloth contours to any lane and any lane surface
- Automatic action ratchet advances duster cloth with no fuss
- 43" wide duster cleans the entire lane in one pass
- Lightweight for easy maneuvering
- Installing clean duster cloth is a snap



LANE MAINTENANCE APPLICATOR

61-860230-000 - (Complete applicator)

When cleaning lanes by hand, there's no better tool to use.

- Reinforced handle won't break or bend as you apply pressure
- Grips terry cloth lane towels for heavy-duty lane cleaning
- Replacement Pad (NEW) 61-100272-000

62-860101-000 - Channel Mop Complete

62-860103-000 - Channel Mop Heavy Duty Refill

LANE CLEANING AND DUSTING TIPS

- Check the condition of the cleaning pad or cushion roller
- View the lane machine spray pattern
- Be sure spray jets are not clogged
- Inspect the condition and adjustments of squeegee blade(s)
- Are lanes air-drying or is cleaner being removed by your machine?
- Be sure to dust your lanes daily from pin deck to foul lines, prior to cleaning
- Avoid using hard water to mix your cleaner, as hard water reduces a cleaner's effectiveness
- Test your lanes regularly to verify the effectiveness of your cleaning system.
- Verify cleaner supply tank is full before cleaning lanes



PRECISION GUTTER AND CAPPING MOPS

62-860093-000 - (Set of two mops)

Cut cleaning time in half by using these convenient mops.

- Specially designed mop head cleans cap and gutters at the same time
- One mop has a larger head for ball return caps and gutters, the smaller mop cleans division caps and gutters
- Package comes complete with one mop of each size
- Mop head made from strong woven yarn that grabs dust from caps and gutters
- Heavy-duty reinforced stitching prevents lint-free yarn from coming loose
- Mop heads are machine washable
- Swivel handle for easy operation

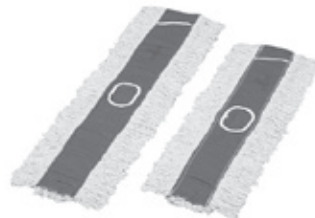

PRECISION GUTTER AND CAPPING MOP REFILLS

62-860094-000 - (Set of two mop heads)

Don't let old, worn mop heads increase work by forcing a need to double run the gutters.

- Replace the old ones with clean, new mop heads
- Same high-quality mop heads as the original
- Heavy-duty reinforced stitching, strong lint-free cotton yarn, and machine washable
- Set comes complete with one larger mop head for ball return caps and gutters and one smaller head for division caps and gutters



APPROACH MOP

62-860095-000 - (Complete mop)

62-860096-000 - (Mop head refill)

Keeping approaches clean is essential for optimum sliding conditions.

- 36" wide mop head is ideal for dusting approaches
- Durable cotton yarn head attracts dust and dirt, leaving approaches clean
- Washable and replaceable

MAINTENANCE SUPPLIES



IPA 99 SYNTHETIC APPROACH CLEANER

61-860254-000 - (12 x 1 Quarts with 4 sprayers)

61-860255-000 - 4 refill bottles (1 Gallon each)

Synthetic approaches require cleaning with a product that won't leave moisture on the approach surface. IPA 99 effectively "conditions" a synthetic approach after it has been spot cleaned; it also displaces surface moisture as part of a regular synthetic approach maintenance program.

- Convenient 1 quart spray bottles with sprayer
- One gallon refill containers
- Pulls moisture from synthetic approaches
- Not recommended for use on wooden approaches



APPROACH DRY SLIDE

62-860210-600 - (12 x 11.2 oz. Canisters)

Approach Dry Slide is a non-abrasive powder used to eliminate sticky approaches. It can be used on both wood and synthetic approaches and is easy to apply. Offered in convenient 11.2 oz. shaker canisters for ease of application.

- Non-abrasive
- Eliminates sticky approaches
- Used on both wood and synthetic approaches
- Best product offered to eliminate sticky approaches



APPROACH SPOT CLEANER

62-860034-004 - (4 x 1 Gallons)

Keep approaches looking clean and spotless.

- Removes dirt and heel marks fast and efficiently
- Solvent-based cleaner dries quickly
- For use on all approach surfaces



APPROACH TREATMENT

62-860078-001 - (4 x 1 Gallons)

Take the stickiness out of approaches.

- Improves slide conditions for sticky approaches
- Provides long-lasting, effective treatment on both wood and synthetic lanes



ARMOR SLIDE

62-860024-000 - (2 Gallons)

Give synthetic approaches better slide characteristics, use Armor Slide.

- General purpose approach aid improves approach performance
- For synthetic approaches only



AEROSOL APPROACH SPOTTER

130190 - (12 x 13.5 oz.. cans)

- Easy to use
- Great for quick spot cleaning



AUTOMATIC PINSETTER CLEANER

62-860083-005 - (5 Gallons)

Here's an effective way to degrease and clean metal pinsetter parts.

- Strong, solvent-based cleaner cuts through tough pinsetter grease and grime
- Note: Do not use on nonmetal parts



BRUNSWICK LIQUID FRICTION PIN DECK TREATMENT

62-860138-000 - (2 x 1 Gallons)

Plus empty pint spray bottle per carton

Effectively ends out-of-range and sliding pin problems. Also quickly and effectively increases the coefficient of friction of pins decks, promoting falling pins over sliding pin action.

- Easy to use. Just spray and dry
- Works effectively on wood or synthetic pin decks



DECK CHUTE CONDITIONER

62-860029-000 - (1 Quart)

Improve the durability and performance of deck chutes. Longer lasting and more stable, this Advanced Performance deck chute conditioner has been designed to minimize deck jams by allowing pins to slide easily through the chutes.

- Improved formula promotes longer chute life
- Durable and more stable
- Minimizes deck jams and downtime

MAINTENANCE SUPPLIES



BRUNSWICK RENTAL SHOE CLEANER

61-860062-000 - (12 x 15 oz. cans)

- Specifically formulated to clean bowling rental shoes
- Clean, fresh scent to please customers
- Keeps front desk storage area clean for a pleasant work environment
- One 15 oz. can cleans approximately 300 pairs of shoes



TILE-LASTIC WAXLESS FLOOR COATING

1905611 - (4 x 1 Gallons)

- Contains no wax. Easy to apply. Dries quickly
- Needs no buffing or polishing
- Can be used on all types of floors



COMMAND NETWORK™ TEAM SCORING RECAP FORMS

57-860422-000 - (4-part form/pkg of 750)

- Use this special NCRTM paper in Command Network printers
- Distribute forms to team captains, league secretaries, offices/managers, newspapers, or others who could benefit from the scores



GREY AUTOMATIC PINSETTER PAINT

62-860062-000 - (One 12 oz. can)

Keep the pinsetter looking as good as new. Fix nicks, scratches and scrapes quickly and easily.

- This is the original grey paint used on the automatic pinsetter
- Convenient spray paint dries quickly to a durable finish
- Available in a 12 oz. aerosol can



FACTORY FINISH BUFFING COMPOUND

14-800009-000 - (2 compound blocks per pkg.)

Utilizes the same ball polish products as our manufacturer. Helps restore your ball to its out of the box look. Factory Finish can be used with plastic, urethane or performance balls.

- Fits Ballworx, LustreKLEEN, and Lustre King ball polishing machines
- Factory finish gloss for all balls
- Replaces Brunswick Lustre Sheen, LustreKLEEN and DBA Blue Genie compounds



REPLACEMENT SPOUT FOR CONDITIONER CONTAINERS

14-100355-001

NOT for No-Spill Mixing Vessel.



NO-SPILL MIXING VESSEL FOR LANE CLEANERS

14-860209-000

- Patented technology
- Controls liquid flow to cleaner tank
- Convenient no-spill container
- Holds 2.5 Gallons of mixed cleaner

LANE MACHINES



MAX LANE MACHINE

48 Ahr Lithium, Power Cord backup

R8-050200-001 - Black covers (115V)

R8-050200-002 - Green covers (115V)

R8-050200-201 - Black covers (230V)

R8-050200-202 - Green covers (230V)

Power Cord

R8-050000-001 - Black covers (115V)

R8-050000-002 - Green covers (115V)

R8-050000-201 - Black covers (230V)

R8-050000-202 - Green covers (230V)

MAX – the new leader in lane machine technology, features Brunswick’s Direct+ Conditioning system. Built to deliver superior performance, reliability, and consistency, MAX is very easy and intuitive to operate. MAX is designed to make lane care easy, reliable, and customized for the needs of bowling centers across the world.

The Direct+ injection system provides individual board-by-board application for superior pattern consistency. The pattern application is not dependent upon machine speed or applying oil on the return pass. Complicated patterns can be laid quickly and precisely. That is why the Direct+ technology has been the choice of the PBA for the past 12 years.

MAX FEATURES

COVERS

The MAX covers are a vacuum formed polymer providing exceptional durability and scratch resistance. Stiff enough to provide needed durability but flexible enough to withstand impacts. They are securely latched ensuring safe and easy transport.

The color goes throughout the cover minimizing the visibility of any scratches. Available in two color options – Black and Electric Green.

FLEX POWER

MAX can be quickly switched between Lithium battery or AC/DC Power. Equipped with an on-board power supply, plugging in the power cord for a seamless transition between these options. The Lithium battery uses a smart charger to optimize battery life and performance. The charging cycle and battery use are monitored and logged through the User Interface. A buzzer will alert you if the machine is not charging after use. If the unexpected happens and the battery was not charged, your machine can be ready to go with the back-up power cord.

USER INTERFACE

MAX features a 10.4" Android-based touch screen tablet that is easy and intuitive to use. This is the same functional and durable tablet used in Brunswick's SYNC™ scoring and management system. The tablet features a large screen with easy-to-navigate main menus across the top and sub menus on the left.

The tablet is also WiFi enabled, allowing for direct Internet communication between Brunswick and the lane machine. This will enhance and quicken any needed support and technical assistance. Pattern download times are also greatly improved.

Predictive analytics are included in the software allowing the user to quickly check specific parameters to ensure the machine is functioning at maximum performance and efficiency.

QUALITY IN THE DETAILS

A single ergonomic button is conveniently located on the handle for ease-of-use. Multiple speed sensors ensure speed consistency. A very robust electronic enclosure contains connections and relays strong enough to withstand the constant demands of daily lane maintenance. The on-board heater promotes consistent oil flow while the buffer brush tapers the pattern for smoother transitions.

WARRANTY

MAX comes standard with a two-year warranty. A warranty extension of one year is available.

CLEANING SYSTEM

The cleaning squeegee has been engineered with ease of adjustment as a key feature. This ensures the appropriate amount of contact with the lane resulting in superior lane cleaning.

A cleaner pressure sensor monitors the cleaning pressure and generates an error message if the pressure becomes too high or too low, allowing for a quick and easy fix.

CONTAMINATION SENSOR

Patent Pending

MAX features a patent-pending sensor system that alerts the user when cleaner has entered the conditioner tank. Once cleaner is introduced into the machine's system, a complete system purge is required. This sensor won't allow the cleaner to leave the conditioning tank by automatically shutting down the machine and providing an error message. The conditioner tank can then be cleaned without adversely affecting other components in the conditioning system.

DIRECT+ CONDITIONING

Patent numbers 7,014,714 and 7,611,583 MAX features our patented Direct+ Conditioning system, which applies the oil with 39 individual injectors – one for each board. This board-by-board approach ensures precise delivery onto the lane, exactly where you want it, regardless of topography. The result is superior pattern consistency with no zigzags or multi-component transfer systems to blur the results.

With Direct+ Conditioning you know the right amount of oil is on the lane. Oil application is computer controlled by varying the injector pulse rate, not the speed of the machine.

The on-board heater warms the conditioner to 80°F ensuring consistent application, while the buffer brush tapers for smoother transitions.

The PBA® counts on Direct+ Conditioning to provide consistent patterns for the very stringent requirements of the PBA Tour. The Direct+ Conditioning system has been used for every PBA Tour event since 2006.

SUPERIOR PATTERN CONTROL

MAX comes pre-programmed with high-performance conditioner patterns that can be graphically display and easily customized. Paired with the Brunswick Pattern Manager software it is easy to create your own pattern library and transfer patterns to the machine as well as make backups of the machine log files and data.

PATTERN MANAGER SOFTWARE

The Brunswick Pattern Manager is a program developed specifically for Direct+ Technology users. It allows you to easily manage your patterns and download them to your lane machine. Included in the Pattern Manager is the Pattern Editor which allows you to create new or edit existing patterns. The log files enable you to see how the lane machine is being used each day. Patterns can be downloaded from the Brunswick Pattern Library to your PC for use in your Brunswick MAX lane machine.

BRUNSWICK PATTERN MANAGER SOFTWARE

14-860027-000

Brunswick Pattern Manager is a program developed specifically for Direct+ conditioning technology users. The Brunswick Pattern Manager allows you to easily download patterns from the Brunswick Pattern Zone and transfer them to your Envoy® or Authority22 lane machine.

BRUNSWICK PATTERN EDITOR SOFTWARE

14-860028-000

The Pattern Editor is a plug and play software that allows you to edit and/or create your own patterns. This add on software to the Pattern Manager helps you build your own library of patterns to meet the needs of your bowlers.

PHOENIX® LT4 LANE MACHINE

R8-010061-000 - (110V 60 Hz)

R8-010062-000 - (220-230V 50Hz)

The Phoenix LT4 is an affordable lane machine designed specifically for centers 16 lanes or less. New features have been added to enhance this easy to operate combination machine which cleans, oils and buffs in a single pass. The Phoenix LT4 is an efficient and affordable solution for your small center's lane maintenance needs. Enjoy the simplicity of operating a LT4.

- Clean and condition a 16 lane center without stopping to refill cleaner and conditioner tanks or emptying the waste tank
- Easy to use so that "anyone" can program or operate the Phoenix LT4 with little or no instruction
- New 4 pattern option provides both open and competitive bowling conditions
- Simple and intuitive operation allows for quick training



LANE MACHINES



ENVOY+

ENVOY+ is the ultimate overhaul for Envoy. Purposefully designed to improve reliability, ease of use, and aesthetics of your lane machine.

The ENVOY+ Upgrade Kit consists of: two 10.4" Android based touchscreen tablets, a new set of black covers, and the necessary adaptor cabling and hardware for installation. This kit gives you the look and feel of our best-selling MAX lane machine, but in a package that is exclusive to current Envoy owners, and at a fraction of the cost.

Your center might not be ready to upgrade to a MAX lane machine, and that's alright. We designed and built your Envoy to last. But we live in a world of touchscreen devices, you should expect nothing less installed in your lane machine. Upgrade today to ENVOY+ and elevate your lane maintenance to the next level.

ENVOY+ UPGRADE KIT - R8-040000-206

QTY	Description
(2)	ENVOY+ tablets
(2)	ENVOY+ side graphics
(1)	Complete left hand top cover (Midnight Black)
(1)	Complete right hand top cover (Midnight Black)
(1)	Cable adapter for tablet to keypad
(1)	Cable from enclosure to tablet
(1)	Combo drill and tap bit (#10-24)
(2)	Bump stops
(6)	Top cover shims
(1)	Cleaner pressure jumper
(2)	Square Bumpers (0.23" thick)

TOP MOVING LANE MACHINE PARTS

MAX, ENVOY+, AND ENVOY®

11-655070-000	Spray Tip - 110 Deg, .05 GPM, S.S.	11-655089-000	Fitting- Male Conn 3/8 Tube	14-100406-000	Assy - Line Strainer, Cleaning Systm
11-655073-000	Gearbelt-1/2 Wide x 3/8 Ptxh x 28.5" Lg	11-672528-000	Relay - Power, T9A	14-100755-091	Assy, Condition Pump w/ Fittings
11-655078-002	Hose - 1-1/2" x 27" Wire Sppt PVC	11-696006-000	Circuit Breaker - Thermal 25 Amp	14-100758-091	Assembly, 24V Cleaner Pump
11-655086-000	Strainer - 100 Mesh Screen	14-100235-091	Pk-Assy, Cable End Lane Sensor	14-100914-000	Assy - 24VDC Vac Motor With Con Seal

MAX, ENVOY+, ENVOY, AND AUTHORITY22®

11-537051-000	Grip-E Ring .250 Dia - Buffer/Idler	11-655057-000	Fitting 90 Degree Street Elbow 1/8	14-100355-000	Spout - Nozzle/Funnel w/ 38mm Redr Colr
11-600010-000	Master Link 1/4" #25 Assy	11-655063-000	Fitting Male Conctct 3/8 Tube x 1/8 NPT	14-100378-000	Foam - Vacuum Diffuser
11-616025-000	Switch-Duster Cloth Up/Dn Lever Type	11-655065-000	Dial-Pressure Gauge, 2 Dia 0-60 PSI	14-100390-000	Foam - Middle Frame Section
11-616026-000	Switch-.1A@125VAC, Buffer/Sq Up/Dwn	11-655084-004	Filter - Screen Only, 100 Mesh	14-100393-000	Assy - Handle Keypad w/ Backer Plate
11-655004-000	Retainer - Tip, Cleaner Spray	14-100030-000	Assy - Mid Guide Wheel (Conical)	14-100427-000	Foam - Buffer Shield Drip
11-655024-000	Assy - Oil Prefilter 40 Mesh w/o Fit	14-100036-000	Assy - Guide Wheel, Mid	14-100430-000	Grommet - Conditioner/Cleaner Tanks
11-655024-004	Prefilter - Oil, Screen Only, Cyl 40 x 30	14-100043-000	Assy - Buffer Brush	14-100437-000	Cap - Conditioner Tank
11-655029-001	Filter - Spin-On Oil, 10 Micron	14-100104-000	Felt - Vacuum Deflector	14-100487-000	Seal - Waste Tank, "D" Shape
11-655040-000	Fitting - Swivel Male Elbow 3/8 x 3/8	14-100106-000	Felt - Vacuum Deflector, Side	14-100521-091	Pk-Assy Absorbent Wiper V-Squeegee
11-655043-006	Nozzle - 3/8ODX .295IDX 20"Lg A22	14-100138-000	Caster - R3" Swivel	14-100523-091	Pk-Assy Blade, V-Squeegee
11-655044-000	Assy - Filter 200 Mesh w/o Fittings	14-100139-000	Assy Swivel Caster 3" Dual Wheel	14-100531-000	Assy Transition Wheel
11-655044-004	Filter - Screen Only, Cyl. 50 x 250M	14-100141-000	Block - Over Travel Upper A22 L/M	14-100543-000	Assy Over Travel Block
11-655048-000	Fitting - Male Conn 3/8 Tube x 1/4 NP	14-100254-000	Assy - Cable, Speed Sensor	14-100556-091	Assy HP Absorbent Wiper V-Squeegee
11-655052-000	Fitting - Tube 1/4 Od x 3/8 Stem Od	14-100279-000	Assy - Front Wheel Guide (Conical)	14-100557-000	Foam Buffer Shield Drip, High Perfmc
11-655053-000	Fitting - 90 Degree Fixed Elbow	14-100323-000	Injector - Conditioner	14-100580-000	Foam - Conditioner Tank Neck
11-655054-000	Fitting - Male Connector 1/4 x 3/8 NPT	14-100353-000	Assy - Line Strainer, Cleaning System	14-860242-000	Pkg - Fuse, 2A 250V Slow 5mm x 20mm

AUTHORITY22

11-106649-000	Bolt - 3/8-16 x 1/2 OD x 2-1/2" Shdw/Ptch	11-695010-000	Caster - 02" Dual Wheel	14-100349-000	Motor - Gearmotor, Buffer Up/Down
11-616029-115	Switch - Hi-Inrushm 1350 Series 115V	11-696946-000	Wheel - 8" Authority22	14-100363-000	Foam - Buffer Brush Shield
11-616030-115	Circuit Breaker - Thermal 115V	11-696956-000	Sensor Horizontal Level Gentech	14-100424-000	Grommet - Tank Level Sensor
11-655002-000	Check Valve/Strainer-200 Mesh Clean	14-100081-002	Foam Tube - Duster, 1.62 ID x .75 x 43 L	14-100481-000	Assy Conditioner Filter
11-655003-000	Nozzle - 110" Cleaner	14-100086-001	Valve - Solenoid w/ Conn, Brass Oil	14-100498-000	Assy Emergency Stop, Lane Machine
11-655013-010	Tube - 1/4 OD x .170 ID x 20" Lg A22	14-100116-000	Rear Wheel Mount Chassis	14-100550-000	Assy Cleaner Nozzle Body, Lwr Manfld
11-655022-000	Gearbelt - Synchronous, 1/2 W x 3/8 P	14-100126-000	Blade-Squeegee 60 Duro Flat Urethane	14-860208-115	Pkg - Power Cord, Lane Machine 115V
11-655034-000	Hose - 1.25 ID, 24" Lg, Vacuum	14-100157-000	Power Supply - Meanwell SP-500 Series	14-860216-000	Pkg - Fuse, 10A, 250V Slow, 5mm x 20mm
11-655035-000	Cuff - Hose Cuff, Grey Vacuum	14-100275-XXX	Assy - Vacuum Motor w/Connectors	14-860218-000	Pkg - Fuse 6.3A, 250V Slow, 5mm x 20mm
11-655061-000	Union "Y" 1/4 Tube	14-100277-000	Assy - Duster Motor w/Connector	14-860228-XXX	Pkg Cleaner Pump Assy
11-655102-000	Assembly, Y, 1/4" Tube x 3/8" NPT	14-100282-001	Assy - LH Transition/Guide Wheel	14-860229-XXX	Pkg Conditioner Pump Assy
11-685071-000	Fuse - 3.15 Am 250V Slo Blo, 5mm x 20mm	14-100282-002	Assy - RH Transition/Guide Wheel	14-860240-000	Pk 1-A22 Hvy Duty Dual Caster w/Hrdw

PHOENIX® LT4

294116126	Spring, Transfer Roller Assy (LT4)	748901031	Fuse 5 x 20 Mm Slo-BI (LT4)	01-109	Flat Washer #8 (LT4)
294116137	Squeegee (LT4)	951638078	Washer, #10, External Tooth Lock, SS	01-123	Screw, Phillips Fh 10-32 x 5/8 (LT4)
294116141	Agitator Foam Shim (LT4)	01-009	Screw, Panhead, 8-32 x 3/8 (LT4)	01-229	Nut #6-32 Nylon Lock Zinc (LT4)
294116142	Agitator Foam (LT4)	01-021	Screw 10-32 x 1/2 (LT4)	04-093	Dip Stick Seal (LT4)

PHOENIX LT4 AND MODEL B

01080	Pin - Cotter 1/16 x 1/2 Phoenix Lite	294115287	Pump - 220V 50/60 Hz Ce	294115652	Replacement Foam Low Output
04128	Tygothane Tubing (Per Ft)	294115404	Wheel - Drive	294115737	Idler Wheel Assy LH/RH
04443	Support Grip	294115482	Replacement Foam Med Low Output	808533167	Screw, Button Head 8-32 x 1
294002033	Solenoid 3000 Series LH Term 110V	294115484	Replacement Foam Medium Output	02-335	Switch, Handle
294002275	Solenoid - 240V 50Hz Rh 3	294115486	Replacement Foam Strip Mho Beige	04-322	Filter Bowl
294002401	Strainer, Check Valve	294115488	Replacement Foam Strip Ho Beige	A0024	Spring - Roller Guide
294002404	Tip Retainer	294115490	Replacement Foam Strip Sho Beige	A0025	Base - Pl Ny Guide Rlr Wa
294115046	Encoder	294115509	Oil Tank Gasket	A8307	Waste Tank Seal
294115072	Stem Adapter 3/8 MPT x 3/8	294115525	Cleaner Tank-Phoenix Lite Lm	SA0244	Guide - Wheel Assembly
294115073	Union Elbow 3/8 x 3/8	294115614	Caster 2"	SA1182	Assy - Oil Brush Tube

PHOENIX MODEL B

294002406	Spray Nozzle	294115070	Washer, Viton	294115375	CW Fuse 250V 8.0A Fast Blow
294002407	Spray Nozzle - Outside	294115113	Vac Hose Assembly	294115419	Fuse 500 MA
294115029	Cleaner Foam	294115166	Fuse - 4A Subminiature T	294115615	Caster 3"
294115049	Belt - Buffer Brush	294115366	Fuse - 2A Subminiature	294115656	Cleaner Foam (Agitator)
294115057	Lane Caster - Phoenix Lite	294115367	Fuse - 5A Subminiature	294115672	Oil Tank Drop Foam
294115068	Nozzle Tip - Orange	294115373	Fuse - 10A Relay Board Fuse	SA-3012	Duster End Plate Roller
294115069	Nozzle Tip - Green	294115374	Fuse - 6.3A Relay Board Fuse	SV72	Squeegee - VLS, 89, 90

OTHER PARTS

1530001	Transport Caster 3" 1/2" Bore	1538207	Squeegee Brake Motor Assy	1548805	Vacuum Motor Assy 115/120V Kustodian
1530002	L/W Lane To Lane Casters 2"	1538310	Lane Edge Guide Roller	1548817	Check Valve Assembly For Tank Vent
1530207	Spray Tip - Stainless Steel (8003)	1538407	Buffer Brush Assy (3-3/4" Dia)	1548867	In-Line Cleaner Filter
1530217	Connector - Male Body 1/4 Nylon	1538410	Assy, Lane Edge Gd Rol w/Bshng	1549201	Timing Belt For Head Drive
1530218	Tip Retainer Cap Connector	1538838	Cushion Rlr Assy w/Stems-Px Pxs XL	1530202B	Squeegee Blade Blue Ea Lcm and Ar
1530220	Screen Check Valve Polypropylene 10#	1541262	Fuse-Time Delay (.75A Mdl) UL	1530202C	Squeegee Blade, Brown Ea
1530812	Transport Caster Heavy Duty 2"	1541269	Fuse Time Delay (6A Mdl) UL	1532540A	Spring For Wiping Pad (1-3/4")
1531027	Solenoid 110V	1548617	Pattern Smoothing Pad Assy-Standard	1538827T	1-1/4 PVC Elbow For Recovery Tank
1536252	Spray Jet Body	1548641	Buffer Brush Assembly-Std 3-3/4 Dia	1541250A	Emergency Stop Circuit Breaker Assy
1538204	Squeegee Blade Rplmnt - Pr Blue	1548684	Recvry Tank Repl. Filter For 1548683	1548617V	Velcro Strip 1/2" x 4-3/8"

LANE FINISH



BRUNSWICK UNI-FLEX BASECOAT

62-860153-005 - (5 Gallons)

Produces unmatched adhesion with the safety and convenience of a water-based finish.

- This durable water-based basecoat is easy to apply with the Slide-In Applicator (61-860183-000) and Water-Based Finish Slide-In Applicator Refills (61-860184-000) or with the Astro E-Z Plus Applicator (61-860241-000) and Foamback Applicator Refill (61-860243-000)
- Dries quickly. Often in less than an hour
- Offers a high degree of flexibility to expand and contract with the lane, greatly reducing cracking, chipping, bruising, and feathering
- Recommended for new or uninjected lanes
- Nonflammable and virtually odorless
- Use in a three-coat system with two coats of Brunswick Hydrolane Topcoat
- VOC compliant in all restricted areas
- Includes additive and whitener
- Each container coats up to seven lanes

UNI-FLEX WHITE ADDITIVE

62-860301-000 - (3 oz. bottle)

Included with Uni-Flex Basecoat.

UNI-FLEX CATALYST

62-860201-000 - (12 x 13 oz.)

Included with Uni-Flex Basecoat.



SHIELD URETHANE COATING

62-860063-001 - (Gallon)

A routine coat of Shield urethane decreases wood damage and increases pin deck life.

- Use on wood pin decks, flat gutters and kickbacks
- Easy-to-apply clear urethane coating dries to a smooth, durable finish
- One gallon covers approximately 300 to 500 square feet
- Note: Brunswick Shield contains volatile organic compounds (VOCs). Before using, check local regulations for VOC restrictions



BRUNSWICK HYDROLANE™ TOPCOAT

62-860200-005 - (5 Gallons)

Get an unbeatable combination of exceptional durability and consistently high-scoring characteristics.

- Textured surface holds conditioner in place to help minimize changing lane conditions as bowling progresses
- Extremely durable water-based finish provides a full season of service in most lineage situations, virtually eliminating the need for midseason recoating
- Low odor and nonflammable to help minimize shut-down time
- Easy to apply. Dries completely in four to six hours
- Use over Astrolane 100 Basecoat, E-Z Basecoat or Brunswick Uni-Flex Basecoat
- Apply using Slide-In Applicator (61-860183-000) and Water-Based Finish Slide-In Applicator Refills (61-860184-000) or with the Astro E-Z Plus Applicator (61-860241-000) and Foamback Applicator Refills (61-860243-000)
- VOC compliant in all restricted areas
- Includes additive
- Each container coats up to seven lanes

HYDROLANE CATALYST

62-860202-000 - (12 x 13 oz.)

Included with Hydrolane Topcoat.

HYDROGLOW ADDITIVE

62-860500-000 - (1 x 14 oz.)

The perfect glow-in-the-dark additive for water-based topcoat finishes.

- One 14 oz. additive per five gallons of Hydrolane water-based topcoat provides excellent glowing lanes when exposed to UV lighting
- Not for use with water-based approach finish



ASTROLANE® SEALER

62-860130-000 - (1 Gallon kit)

This fast-drying, pre-base coat stain and sealer coat gives older, oil-soaked wood lanes a lighter appearance and allows the base coat to protect the lane.

- Two component, 100% Solids type formulation
- VOC Compliant
- Prevents base coat from soaking into wood
- Results in a smoother, higher-gloss lane finish system
- Apply with Astrolane 100% Solids applicator assembly (14-860111-000) and 100% Solids applicator refills (14-860108-000)
- One gallon kit covers 8 lanes



ASTROLANE® WB APPROACH FINISH

62-860019-000 - (Four 1 Gallon containers)

62-860019-001 - (1 Gallon)

This great looking approach finish is a favorite of industry professionals.

- Highly durable approach finish rarely needs midseason recoating
- One-coat application dries in one to three hours
- Clean up with soap and water
- Provides uniform slide characteristics
- Resistant to toe and ball marking
- Apply using Approach Applicator (61-860110-000) and Approach Applicator Refill (61-860110-005)
- VOC compliant in all restricted areas
- Each gallon coats up to six approaches



ASTROLANE® 100 TOPCOAT

62-860124-000 - (Glow-in-the-Dark)

62-860005-000 - (Non-glow)

Choose the finish that others strive to match.

- Astrolane 100 Topcoat is the industry standard for durability and appearance
- It's so durable that it often lasts a whole season under normal conditions, virtually eliminating the need for midseason recoating
- Nonflammable with low odor
- Sold in cases of eight kits. One kit per lane
- Apply using 100% Solids Applicator and 100% Solids Applicator Refills (14-860108-000)
- VOC compliant in all VOC restricted areas



ASTROLANE® 100 BASECOAT

62-860018-000

Team up this premium basecoat with Astrolane 100 Topcoat for the best system in the industry.

- Offers a solid foundation for Astrolane or other finish systems
- May be used with a variety of lane finish topcoats
- Excellent adhesion characteristics provide superior durability and long life
- Features a special lightening agent to enhance the natural beauty of pine and maple
- Gives old lanes the lighter, cleaner look of new wood
- Nonflammable with low odor
- Sold in cases of eight units. One kit per lane
- Apply using 100% Solids Applicator and 100% Solids Applicator Refills (14-860108-000)
- VOC compliant in all VOC restricted areas



U-300 SINGLE PACKAGE ULTRAVIOLET FINISH

62-860172-005 - (5 Gallons)

This moisture-cure urethane topcoat looks completely clear under standard lighting, and emits a blue-white aura under ultraviolet conditions.

- Hard, durable finish that requiring no additional clear topcoat
- Each container coats up to seven lanes
- May not be permitted in your area due to local VOC restrictions; check your local VOC regulations or contact your Brunswick distributor for details



ASTROLANE® E-Z TOPCOAT

62-860088-001 - (One 1.7 Gallon kit)

COSMIC ASTROLANE® E-Z TOPCOAT

62-860119-000 - (One 1.7 Gallon kit)

Easy-to-use topcoat combines the strength and durability of 100% solids technology with the ease of conventional lane finish application.

- Extremely durable urethane finish with the same beautiful appearance as Astrolane 100 Topcoat
- A favorite of top-notch resurfacers
- Apply with Astrolane E-Z Plus Applicator (61-860241-000) and Regular Nap Applicator Refill (61-860247-000) or with Regulator Nap (Slide-In) Refill (61-860385-000)
- Can be used to recoat a variety of compatible lane finish topcoats
- VOC compliant in all VOC-restricted areas
- Each kit coats five lanes



ASTROLANE® E-Z BASECOAT

62-860100-000 - (One 1.7 Gallon kit)

Outstanding adhesion and a durable basecoat with conventional application.

- Two-component urethane system
- Applied with Astrolane 100 E-Z Plus Applicator (61-860241-000) and Foamback Applicator Refill (61-860243-000)
- Works well with any water-based moisture-cure, urethane, or E-Z Topcoat
- VOC compliant in all VOC-restricted areas
- Each kit coats five lanes

FINISH APPLICATORS

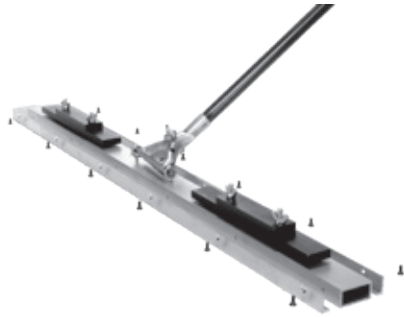

UNIVERSAL LANE FINISH APPLICATOR
61-860188-000

This economical applicator is designed for conventional application of water-based, moisture-cured urethane and Astrolane E-Z lane finishes.

- Designed to give the user the best view of the finish “puddle” to eliminate mistakes
- Slide-in applicator is easy to assemble
- Includes three sizes of adjustable weights to control film thickness
- Designed for use with Slide-In Applicator Refills
- Not designed for use with 100% Solids coatings



ASTRO E-Z PLUS APPLICATOR
61-860241-000

Designed for conventional application of most bowling lane finishes and a must for application of E-Z Basecoat and Topcoat.

- Ideal for application of water-based urethane and moisture-cure urethane, Astrolane E-Z Basecoat and Astrolane E-Z Topcoat
- Application is simplified. No need to carry a heavily weighted applicator from lane to lane
- Not designed for use with 100% solids coatings
- Use with specially designed adhesive-backed Astro E-Z Plus Applicator Refills

WATER BASE APPROACH FINISH APPLICATOR

62-862120-000

- For use with WB approach finish
- Use with refill 61-860110-005

APPLICATOR REFILL AND APPLICATOR CHART

Part Number	Description	Applicator
61-860247-000	Regular Nap, Adhesive Refill (box of 6) - NEW!	61-860188-000 and 61-860241-000
61-860243-000	Wide, Foam backed, Adhesive Refill (box of 6)	61-860188-000 and 61-860241-000
61-860244-000	Terry Cloth, Adhesive Refill (box of 6)	61-860188-000 and 61-860241-000
14-860108-000	100% Solids Applicator Refills (box of 2)	14-860111-000
61-860184-000	WB Finish Slide-In Refills (box of 6)	61-860188-000
61-860385-000	Regular Nap, Slide-In Refills (box of 5) - NEW!	61-860188-000
61-860110-005	WB Approach Applicator Refill (box of 6)	62-862120-000

FINISH APPLICATORS



100% SOLIDS APPLICATOR REFILLS 14-860108-000

For a perfect finish application, start by replacing worn or damaged applicator refills.

- Cushioned refill ensures that a smooth contour is applied to all lane surfaces and lane imperfections
- Durable urethane material cannot be damaged by lane finish, so long life is assured
- Refill conforms to exact Brunswick tolerances to assure a consistent and even finish film thickness
- Refill includes ears and foam cushions
- Keep a few in stock to always be prepared
- Two refills per package



APPROACH APPLICATOR REFILL 61-860110-005

This 18" foam-flocked applicator refill is ideal for applying Astrolane WB Approach Finish (62-860019-000).

- Cleans easily with water



REGULAR NAP SLIDE-IN APPLICATOR REFILLS 61-860385-000

This applicator board makes Astrolane E-Z Topcoat and moisture-cure urethane topcoat finish jobs look fantastic.

- Assures a proper amount of finish is applied while eliminating waste and saving money
- Finish flow is consistent, from edge board to edge board
- For use with Astrolane E-Z Topcoat and moisture-cure urethane topcoats
- Installs easily in Slide-In Applicator
- Use with Slide-In Applicator (61-860183-000)
- Package of five

REGULAR NAP ADHESIVE APPLICATOR REFILLS 61-860247-000

- For use with moisture-cure urethane topcoats and Astrolane E-Z Topcoat and E-Z Basecoat
- These adhesive-backed refills ensure quick fastening and removal from the E-Z Plus Applicator Long Nap Applicator Refill
- Package of six



WATER-BASED SLIDE-IN FOAM BACKED APPLICATOR REFILLS 61-860184-000

Perfect for applying water-based finishes.

- Synthetic foam-flocked material ensures that the proper amount of finish is applied every time, eliminating waste and saving money
- Finish flow is consistent across the lane, assuring complete coverage of edge boards
- Use with Slide-In Applicator (61-860183-000)
- Package of six

WATER-BASED ADHESIVE FOAM BACKED APPLICATOR REFILLS 61-860243-000

- For use with all water-based lane finishes
- Package of six

WB Lane	WB Approach	100% Solids	E-Z Base	E-Z Top	Moisture Cure	HS Moisture Cure	Lane Sealer
			X	X	X	X	
X			X				
		X					X
X			X				
			X	X	X	X	
	X						

BANKSHOT BUMPER BOWLING AND FOUL LINE DECAL

BANKSHOT™ BUMPER BOWLING SYSTEM (1 LANE KITS)

171801GK - Medium Gray

171801K - Charcoal

171801MBK - Matte Black

The affordable bumper bowling system that will bring in the bucks, from bumper leagues to bumper birthday parties.

- Easy to install
- Pays for itself fast, turning revenues to pure profits
- Made with all-metal uprights for improved durability and performance
- Goes from up-and-ready to out-of-sight quickly and easily
- Can be automated or integrated with SYNC™, Vector® and Frameworx® scoring at any time
- Bankshot colors complement any décor

BANKSHOT CHANNEL ONLY KITS

171805K - Charcoal Channel Only Kit

171805GK - Medium Gray Channel Only Kit

171805MBK - Matte Black Channel Only Kit

BANKSHOT RAIL UPGRADE KITS

171806K - Charcoal Rail Upgrade Kit

171807K - Medium Gray Rail Upgrade Kit

171806MBK - Matte Black Rail Upgrade Kit

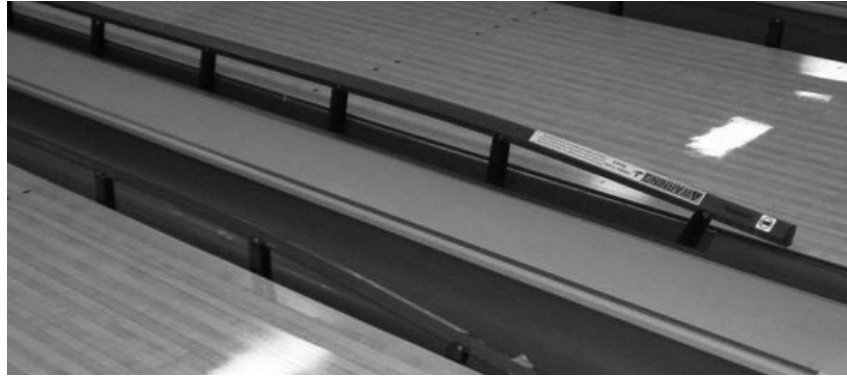

BANKSHOT UPGRADE KITS

84-860703-000 - Gas Spring and Hardware – Single Lane Kit

84-860715-000 - Gas Spring and Hardware – Two Lane Kit

11-210005-000 - Gas Spring only

84-860716-000 - Drill Package for Gas Spring Upgrade

84-860100-000 - Tool Package Improved deployment tool for raising Bankshot

84-860719-000 - Vertical Supports (28 Pk) Includes Washers and Rubber Bushings

84-860720-000 - Vertical Supports (60 Pk) Does NOT include hardware

L2-600074-000 - Short Vertical Upgrade

This new half size support reduces possible damage to the head rail from ball impact. Upgrade package includes 4 short vertical supports with connecting pins.

84-200472-000 - Tool E-Clip Specialty tool for E-clip installation

Part Number	Replacement Rail Sections
84-200478-XXX	LH Pinsetter End Rail
84-200479-XXX	RH Pinsetter End Rail
84-200451-XXX	Common Rail
84-200452-XXX	LH Foul Rail
84-200453-XXX	RH Foul Rail

Part Number	Replacement Rail/Gutter Sections
84-860160-XXX	Pkg-Rail/Gutter Sect LH Foul
84-860161-XXX	Pkg-Rail/Gutter Sect RH Foul
84-860162-XXX	Pkg-Rail/Gutr Sect LH Common
84-860163-XXX	Pkg-Rail/Gutr Sect RH Common
84-860164-XXX	Pkg-Rail/Gutr LH Pinset End
84-860165-XXX	Pkg-Rail/Gutr RH Pinset End

Part Number	Replacement Gutter Covers
84-860622-XXX	Gutter Cover Pkg 118"
84-200465-XXX	Gutter Cover 31.125"

Part Number	Replacement Miscellaneous
84-200457-000	Coupler - Rail
84-200463-002	LH Rail Plug Pkg
84-200463-001	RH Rail Plug Pkg
84-200458-001	Pin - Connecting, Upper Arm
84-200458-003	Pin - Connecting, Rail Joint
84-200487-000	Rubber Bushing - Vertical Support
11-537050-000	Retaining Ring
84-200458-004	Pin - Connecting
84-200462-000	Gutter Coupler
84-200459-000	Pin-Connecting, 1.940" Lg
11-537050-000	Retaining Ring
84-200488-000	Decal - Hand Warning
11-682561-000	Label - Warning For Bankshot
84-200687-000	Gas Spring Lower Bracket
84-200688-000	Gas Spring Upper Bracket

COLOR OPTIONS FOR REPLACEMENT RAIL AND GUTTER

Color	Suffix*
Matte Black	405
Dark Grey	100
Medium Grey	142

FOUL LINE DECAL (PKG OF 6)

84-860266-000 - English

84-860269-000 - Spanish

Help keep your bowlers behind the foul line with this Foul Line Decal. This USBC approved decal is easy and quick to install using the step by step instructions that are included in the package. Made with Guardian, the decal provides great glow under black lights.



RESURFACING SUPPLIES



POWDERED OIL VAC™ LANE OIL REMOVER **62-860074-000**

Do the job right. Properly treat the bare wood before applying the basecoat finish.

Contains a powerful absorbent material for drawing conditioner out of wood.

- Improves adhesion of basecoat finish to wood surface while returning wood to original, natural color
- Specially formulated powder is fast-acting and odorless
- Easy to apply and clean up
- Multiple applications may be required for heavily oil soaked lanes
- One 50 lb. bag covers six to eight heads



PERMA GRIP PAD HOLDER **61-860097-000**

Ensure that the synthetic pads stay firmly in place when cleaning, polishing, or conditioning lanes and floors.

- Features 1/2"-long tufts of untrimmed polypropylene widely spaced on the face of the disc
- The individual filament brushes penetrate the synthetic pad and hold it in place
- Allows operator to heel lane machine without recentering the pad
- This holder is designed so that larger polishing pads can also be used
- **WARNING:** Do not use brush or pad with flammable materials (fuels, solvents, thinners, etc.). Serious injury could result from fire or explosion

ROTARY BUFFER SCREENS

- 61-860034-002** - 80 Grit, 18" Square, Each
- 61-860034-003** - 180 Grit, 18" Square, Each
- 61-860034-008** - 220 Grit, Silicon Carbide, 5pk
- 61-860034-007** - 320 Grit, Silicon Carbide, 5pk

TACK CLOTH

61-860026-250 (250 yard roll)

Eliminate all dust and grit that can interfere with the perfect coating job.

- This sticky cloth attracts and holds particles to produce an extremely clean surface
- Leaves lanes perfectly clean
- Use after screening to pick up dust and particles
- A "must-use" for a professional-looking finish



INJECTION EPOXY

61-860712-005

(White Compound A - 5 Gallon Container)

61-860713-005

(Brown Hardener B - 5 Gallon Container)

More lanes have been injected with this injection compound than all other epoxies combined. With an original process, epoxy is injected into the tongue and groove of lanes, completely filling the areas between the boards, bonding the boards together.

- Eliminates feathering; greatly reduces wood damage due to board movement
- Lanes will last longer. Resurfacing won't require sanding off as much wood
- Use two parts Compound A with one part Hardener B



CLEANING DURA PADS (BLACK)

61-860023-000 - (Package of 10 - Black)

These pads are designed to handle the toughest floor cleaning jobs.

- Excellent for heavy-duty cleaning
- Thin, black pads are constructed from durable, nylon web
- 19" pads fit most floor buffing machines

CAUTION: Test before using. May abrade some surfaces.



19" COTTON BUFFING BONNET PAD

62-860193-000

The 19" cotton buffing bonnet pad can be used with rotary floor machines to buff and polish approaches. For optimal absorption the buffing bonnet should be washed prior to use.



BRUNSWICK INJECTA-PATCH LANE EPOXY

61-860256-000 - (3 oz. cartridge*)

61-860257-000 - (static mix tube for 3 oz. cartridge*)

61-860258-000 - (3 oz. cartridge trigger dispenser)

61-860259-000 - (14 oz. cartridge*)

61-860260-000 - (static mix tube for 14 oz. cartridge*)

61-860261-000 - (14 oz. cartridge HD trigger dispenser)

This epoxy formulation is designed to look more like wood and to sand like wood. The heavy duty, 14 oz. cartridge trigger dispenser has the power to inject epoxy into lanes; more convenient than injection machines for injection repair or lane injection of a few lanes.

- Fast curing
- Sands like wood
- * Sold individually



SCRUBBING DURA PADS

61-860027-000 - (Pkg of 10-Thin, Green) - 20"

61-860117-000 - (Pkg of 5 - Thick, Tan) - 19"

Keep pads in stock to ensure a well maintained center.

- Pads are made from durable, woven nylon fibers
- Excellent for applying conditioner, polishing, and light cleaning duties
- Use with all rotary floor machines
- Wash and reuse
- Available in two thicknesses
- Pads fit most floor buffing machines



TREATED PAPER

61-860032-000 (Sheet)

Capture excess finish while protecting covered surface from damage.

- Specially treated paper prevents finishes from soaking through to the area beneath it
- Reduces cleanup time by collecting excess finish
- Not just for resurfacing work
- Sheet dimensions are 45" x 48"

REPLACEMENT LANE PANELS

7/16" Anvilane™ Lane Panels (special order only)

84-200261-000 - 7/16" Maple Laminate Plate Finish

84-200262-000 - 7/16" Foul Line Laminate Plate Finish

84-200263-000 - 7/16" Pine Plate Finish Panel

84-200265-000 - 7/16" Approach Plate Finish Panel

84-200266-000 - 7/16" Division Plate Finish Panel

84-200267-000 - 7/16" Return Plate Finish Panel

84-200272-000 - 7/16" Head Plate Finish Panel

GID 7/16" Anvilane Lane Panels (special order only)

84-200261-900 - GID 7/16" Maple Laminate Plate Finish

84-200262-900 - GID 7/16" Foul Line Laminate Plate Finish

84-200263-900 - GID 7/16" Pine Plate Finish Panel

84-200265-900 - GID 7/16" Approach Plate Finish Panel

84-200266-999 - GID 7/16" Division Plate Finish Panel

84-200267-999 - GID 7/16" Return Plate Finish Panel

84-200272-900 - GID 7/16" Head Plate Finish Panel

3/8" Anvilane Lane Only Lane Panels (special order only)

84-200718-000 - 3/8" Lane Only LH Foul Line Panel

84-200719-000 - 3/8" Lane Only RH Foul Line Panel

84-200720-000 - 3/8" Lane Only LH Arrow Panel

84-200721-000 - 3/8" Lane Only RH Arrow Panel

GID 3/8" Anvilane Lane Only Lane Panels (special order only)

84-200718-999 - GID 3/8" Lane Only LH Foul Line Panel

84-200719-999 - GID 3/8" Lane Only RH Foul Line Panel

84-200720-999 - GID 3/8" Lane Only LH Arrow Panel

84-200721-999 - GID 3/8" Lane Only RH Arrow Panel

3/8" Non Textured Anvilane Lane Panels (special order only - 89" T-panel)

84-200614-000 - 3/8" LH Approach Panel

84-200615-000 - 3/8" RH Approach Panel

84-200616-000 - 3/8" LH Foul Line Panel

84-200617-000 - 3/8" RH Foul Line Panel

84-200618-000 - 3/8" LH Arrow Lane Panel

84-200619-000 - 3/8" RH Arrow Lane Panel

GID 3/8" Non Textured Anvilane Lane Panels (special order only - 89" t-panel)

84-200614-999 - GID 3/8" LH Approach Panel

84-200615-999 - GID 3/8" RH Approach Panel

84-200616-999 - GID 3/8" LH Foul Line Panel

84-200617-999 - GID 3/8" RH Foul Line Panel

84-200618-999 - GID 3/8" LH Arrow Lane Panel

84-200619-999 - GID 3/8" RH Arrow Lane Panel

3/8" Non Textured Anvilane Lane Panels (special order only - 85.5" t-panel)

84-200663-000 - 3/8" LH Approach Panel

84-200664-000 - 3/8" RH Approach Panel

84-200666-000 - 3/8" RH Foul Line Panel

84-200665-000 - 3/8" LH Foul Line Panel

GID 3/8" Non Textured Anvilane Lane Panels (special order only - 85.5" t-panel)

84-200663-999 - GID 3/8" LH Approach Panel

84-200664-999 - GID 3/8" RH Approach Panel

84-200665-999 - GID 3/8" LH Foul Line Panel

84-200666-999 - GID 3/8" RH Foul Line Panel

Lane Panels Anvilane Non Text 3/8" (special order only)

84-200661-000 - 3/8" Narrow Ball Return Fill Panel

84-200722-000 - 3/8" Walkway Fill Panel

GID Lane Panels Anvilane Non Text GID 3/8" (special order only)

84-200661-999 - GID 3/8" Narrow Ball Return Fill Panel

84-200722-999 - GID 3/8" Walkway Fill

Lane Panels Anvilane Textured 3/8" (special order only)

84-200705-000 - 3/8" Textured LH Common Panel

84-200706-000 - 3/8" Textured RH Common Panel

84-200707-000 - 3/8" Textured LH Arrow Panel

84-200708-000 - 3/8" Textured RH Arrow Panel

84-200709-000 - 3/8" Textured LH Short Panel

84-200710-000 - 3/8" Textured RH Short Panel

84-200711-000 - 3/8" Textured LH Approach Panel

84-200712-000 - 3/8" Textured RH Approach Panel

84-200713-000 - 3/8" Textured LH Foul Line

84-200714-000 - 3/8" Textured RH Foul Line

84-200715-000 - 3/8" Textured Mo Ball Return

84-200716-000 - 3/8" Textured Narrow Ball Return Fill

84-200717-000 - 3/8" Textured Walkway Fill

REPLACEMENT LANE PANELS

GID Lane Panels Anvilane Textured 3/8" (special order only)

84-200705-999 - GID 3/8" Textured LH Common Panel

84-200706-999 - GID 3/8" Textured RH Common Panel

84-200707-999 - GID 3/8" Textured LH Arrow Panel

84-200708-999 - GID 3/8" Textured RH Arrow Panel

84-200709-999 - GID 3/8" Textured LH Short Panel

84-200710-999 - GID 3/8" Textured RH Short Panel

84-200711-999 - GID 3/8" Textured LH Approach Panel

84-200712-999 - GID 3/8" Textured RH Approach Panel

84-200713-999 - GID 3/8" Textured LH Foul Line

84-200714-999 - GID 3/8" Textured RH Foul Line

84-200715-999 - GID 3/8" Textured Mo Ball Return

84-200716-999 - GID 3/8" Textured Narrow Ball Return Fill

84-200717-999 - GID 3/8" Textured Walkway Fill

GID Lane Panels Pro Lane™ (special order only)

84-200436-999 - GID Pro Lane RH Approach Panel

84-200437-999 - GID Pro Lane LH Approach Panel

84-200438-999 - GID Pro Lane RH Foul Line Panel

84-200439-999 - GID Pro Lane LH Foul Line Panel

84-200440-999 - GID Pro Lane Ball Return Fill Panel

84-200445-999 - GID Pro Lane Wide Ball Return Fill Panel

84-200446-999 - GID Pro Lane Walkway Fill Panel

GID Lane Panels Pro Lane Textured (special order only)

84-200696-999 - GID Textured Pro Lane RH Approach Panel

84-200697-999 - GID Textured Pro Lane LH Approach Panel

84-200698-999 - GID Textured Pro Lane RH Foul Line Panel

84-200699-999 - GID Textured Pro Lane LH Foul Line Panel

84-200701-999 - GID Textured Pro Lane Ball Return Fill Panel

84-200702-999 - GID Textured Pro Lane Wide Ball Return Fill Panel

84-200704-999 - GID Textured Pro Lane Walkway Fill Panel

84-200692-999 - GID Pro Lane Head Lane Panel

84-200693-999 - GID Pro Lane Lane Panel

84-200694-999 - GID Pro Lane With Characters

84-200695-999 - GID Pro Lane Short Lane

GID Lane Panels Pro Lane Lane Only (special order only)

84-200700-999 - GID Pro Lane Lane Only Foul Line

LANE PARTS



MAPLE PATCHING STOCK

21-042538-000 - (1 3/32" x 3/4" x LF)

21-033042-000 - (1 9/64" x 3/4" x LF)

Used for repairing unsightly or broken boards in the approach, head or pin deck area.

- Highest-grade clear, select hardrock maple for maximum durability
- Kiln dried for dimensional stability
- Precision-milled for uniformity



PINE PATCHING STOCK

21-033043-000 - (1 9/64" x 3/4" x LF)

Used to repair heavily dented or broken boards in the pine section of the lane.

- Highest-grade select southern yellow pine
- Kiln dried for dimensional stability
- Precision-milled for uniformity

URETHANE FOUL LINE

84-200365-000

MAPLE FACE BOARDS

52-100291-000 - (5-1/2")

52-100473-000 - (6-1/2")



RED FIBER DOWEL

52-200060-000 - (11/16" x 3/4")

Used to replace thin or worn lane marking guides.



PINE DOWEL

52-100211-000 - (11/16" x 2")



MAPLE DOWEL

52-100203-000 - (1/2" x 2")

52-100204-000 - (11/16" x 2")

Used to cover holes when face-screwing a wooden head approach or pin deck.



FIBER BED SPOT

21-016034-000 - (1/2")

High-quality material used to replace thin or broken bed spots.

- Conforms to USBC® specifications for bed spot diameter
- Tough, impact-resistant material for maximum durability

LANE PLUGS

84-860600-999 - Nylon Lane Plug GID (500 Pk)

84-860601-999 - Nylon Lane Plug GID (50 Pk)

84-860600-000 - Nylon Lane Plug (500 Pk)

84-860601-000 - Nylon Lane Plug (50 Pk)

- Replacement plugs for Pro Lane™ or 3/8" Anvilane™ phenolic lane panels

PLYWOOD SPLINE ONE-PIECE TAILPLANK

84-200046-000

- Replaces worn tailplank on pin deck with durable plywood version

MAPLE EPOXY KIT

61-860073-999 - (GID)

61-860073-000 - (Non-Glow)

DOW CORNING 795 SILICONE

84-200430-000 - Sandstone

84-200172-000 - Clear

PRO LANE PANEL SEALER

84-860565-000

LANE PARTS

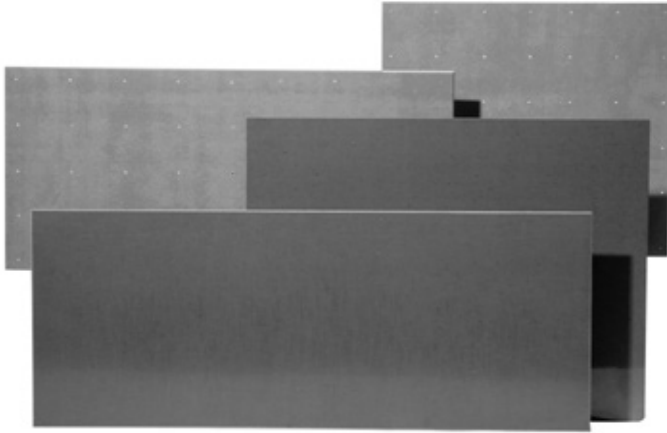

KICKBACK PLATE

52-200005-002 - (R.H. 7-pin side 16" x 40" front plate for GS-Series or armor frame)

52-200005-004 - (L.H. 10-pin side 16" x 40" front plate for GS-Series or armor frame)

52-200005-003 - (29" x 22" rear plate for GS-Series)

21-088674-000 - (21-3/4" x 19" rear plate)

21-088675-000 - (33" x 15" front wood kickback plate)

This solid, active kickback plate will provide improved pin action and more consistent scoring than old, dead plates.

- When kickback plates become soft or loose, they absorb energy from pins, reducing pin action and affecting bowlers' scores
- Durable, impact-resistant plate is made from a solid piece of phenolic material protecting wood kickback from damage over time
- Flexible material won't delaminate or splinter
- All sharp edges are removed to prevent damage to ball and pins
- Surface is non-marking to pins
- Sanded back surface ensures secure mounting. For strongest bond, use Brunswick Adhesive (11-676047-000)
- Predrilled

HDPE KICKBACK PLATES

179855 - HDPE Kickback Plate for AMF 15" x 33" (each)

179858 - HDPE Kickback Plate for Brunswick 19" x 23-3/4" (each)

179855P - HDPE Kickback Plate for AMF 15" x 33" (pre-drilled, each)

179856P - HDPE Kickback Plate for AMF 15" x 50" (pre-drilled, each)

179857P - HDPE Kickback Plate for Brunswick 16" x 40" (pre-drilled, each)

179858P - HDPE Kickback Plate for Brunswick 19" x 23-3/4" (pre-drilled, each)

179859 - Kickback Nails, 1", heat-treated twist nails (pound)

- Increases scoring
- Made of high-density polyethylene material. Never needs coating
- Single-piece construction prevents delamination
- Available pre-drilled



BRUNSWICK HDPE FLAT GUTTER

84-860557-000

- Made from extremely durable high-density polyethylene material
- Quick and easy installation
- Lower maintenance costs. No coating is required
- 52" length can be cut to fit all lane configurations

80108L - Flat Gutter (left-hand side)

80108R - Flat Gutter (right-hand side)

BRUNSWICK HEAVY DUTY FLAT GUTTERS

84-860504-000 - (2 flat gutters per package)

Brunswick's best flat gutter. Virtually indestructible, made of Ultra High Molecular Weight polypropylene.

- Bottom of gutter is 1" thick with 3/4" sides
- Dark brown material won't mar pins or balls
- Easy to clean and maintain
- Sold as two flat gutters for one lane
- USBC Approved

52-100472-001 - HD Gutter (bottom)

52-100472-002 - HD Gutter (RH side)

52-100472-003 - HD Gutter (LH side)

LANE PARTS

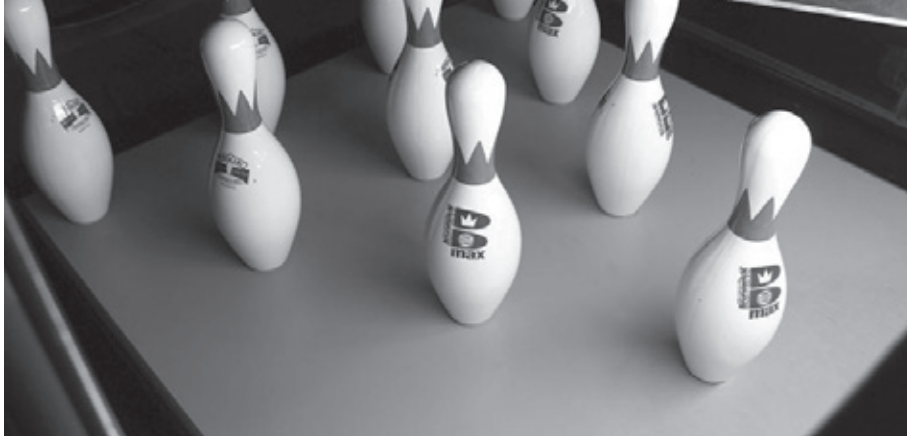

BRUNSWICK ANTI-SKID PIN DECK

418001K - Anti-Skid Synthetic Pin Deck (each/includes adjustable hardware)

418002K - Anti-Skid Pin Deck (top screwed)

418527L - Phenolic Edgeboard (7 Pin Side)

418527R - Phenolic Edgeboard (10 Pin Side)

- Reduces sliding pins
- High-impact surface
- High-density core construction
- Adjustable hardware for replacement installations



SIDE PIN DECK EDGE MOLDING

52-100243-001 - (48" x 2-1/16" for old-style phenolic pin decks/synthetic lanes)

52-100078-000 - (48" x 2-3/4" for old-style phenolic pin decks/wood lanes)

84-200084-010 - (48" x 1-3/8" for integral pin deck/synthetic lanes)

HDPE PIN DECK EDGE BOARDS

179860 - Pin Deck Edge Boards (each)

- Replacement edge boards for wood decks
- Made from extremely durable high-density polyethylene material
- Stronger than wood
- 1" x 2-1/2" x 46"

HDPE TAIL PLANK COVER STRIPS

179861 - Tail Plank Cover Strip (each)

- Replaces entire worn upper sections on tail planks of wood pin decks
- Made from extremely durable high-density polyethylene material
- 1" x 1-3/4" x 43"

REAR PIN DECK EDGE MOLDING

52-100079-000 - (40-3/4" x 2-3/4" for old-style phenolic pin decks/wood lanes)

52-100244-000 - (40-3/4" x 2-1/16" for old-style phenolic pin decks/synthetic lanes)

84-200083-010 - (40-3/4" x 1-3/8" for integral pin decks/synthetic lanes)

Extend the life of the pin deck by protecting its edges properly.

- Tough edge boards made from X-grade phenolic material can withstand the abuse of flying pins
- Rounded edges protect pins and balls from damage
- 1/2" thick for durability
- The 52-100078-000 edge boards have cut-outs to ensure proper fit. Install these edge boards with glue only (no screws necessary)
- When installing edge boards with glue, use Brunswick Adhesive (11-676047-000)



GUTTER HEADER BLOCK

84-200644-000

Provides an improved lane to gutter installation, eliminating custom fitting and preventing dirt from getting trapped underneath the block. An added back stiffener keeps the block from buckling and improves the movement of lane machine wheels into and out of the gutter. It can be used with all Brunswick round gutters and other round gutters.



ADAPTER GUTTER BLOCKS (BANKSHOT/PBW)

84-200456-001 - (R.H.)

84-200456-002 - (L.H.)

Replace worn adapter blocks to ensure proper ball transition from Bankshot or PBW gutters to the flat gutter. Made from polypropylene material for great strength and durability.



GOLD CROWN ORDER FORM - WORLDWIDE

BILL TO (if a credit card sale, card holder's address is required)

SHIP TO (if different from bill to)

0621-65

CUSTOMER NUMBER			CUSTOMER NUMBER		
CONTACT			CONTACT		
BOWLING CENTER			BOWLING CENTER		
STREET			STREET		
CITY	STATE	ZIP	CITY	STATE	ZIP
PHONE (WILL BE USED ONLY IF WE HAVE A QUESTION)		CARD TYPE		CARD NUMBER	
EMAIL		<input type="checkbox"/> Visa <input type="checkbox"/> Am. Express	EXPIRATION DATE (MM/YY) SECURITY CODE		
		<input type="checkbox"/> Master Card <input type="checkbox"/> Discover			
PURCHASE ORDER NUMBER			PURCHASE ORDER TERMS		

PART NUMBER	SIZE/STYLE	QTY	PART NUMBER	SIZE/STYLE	QTY	PART NUMBER	SIZE/STYLE	QTY
6 lb. – Black Pearl			10 lb. – Black Pearl			13 lb. – Black Pearl		
60106562966	NO Drill	_____	60106562930	NO Drill	_____	60106562933	NO Drill	_____
60106562866	XXS-Drilled	_____	60106562630	S-Drilled	_____	60106562533	M-Drilled	_____
60106562766	XS-Drilled	_____	60106562530	M-Drilled	_____	60106562433	L-Drilled	_____
			60106562430	L-Drilled	_____	60106562233	XL-Drilled	_____
			60106562230	XL-Drilled	_____			
7 lb. – Black Pearl			11 lb. – Black Pearl			14 lb. – Black Pearl		
60106562937	NO Drill	_____	60106562931	NO Drill	_____	60106562934	NO Drill	_____
60106562737	XS-Drilled	_____	60106562531	M-Drilled	_____	60106562534	M-Drilled	_____
60106562637	S-Drilled	_____	60106562431	L-Drilled	_____	60106562434	L-Drilled	_____
			60106562231	XL-Drilled	_____	60106562234	XL-Drilled	_____
						60106562134	XXL-Drilled	_____
8 lb. – Black Pearl			12 lb. – Black Pearl			15 lb. – Black Pearl		
60106562938	NO Drill	_____	60106562932	NO Drill	_____	60106562935	NO Drill	_____
60106562638	S-Drilled	_____	60106562632	S-Drilled	_____	60106562435	L-Drilled	_____
60106562538	M-Drilled	_____	60106562532	M-Drilled	_____	60106562235	XL-Drilled	_____
60106562438	L-Drilled	_____	60106562432	L-Drilled	_____	60106562135	XXL-Drilled	_____
			60106562232	XL-Drilled	_____			
			60106562132	XXL-Drilled	_____			
9 lb. – Black Pearl								
60106562939	NO Drill	_____						
60106562639	S-Drilled	_____						
60106562539	M-Drilled	_____						
60106562439	L-Drilled	_____						

PRICE _____

Note: All drilled balls will be engraved with the ball grip size.

Please Fax this order to: 231-725-4429
or email it to: bcss.orders@brunbowl.com



MY BALL™ ORDER FORM - WORLDWIDE

BILL TO (if a credit card sale, card holder's address is required)

SHIP TO (if different from bill to)

1113-07

CUSTOMER NUMBER			CUSTOMER NUMBER		
CONTACT			CONTACT		
BOWLING CENTER			BOWLING CENTER		
STREET			STREET		
CITY	STATE	ZIP	CITY	STATE	ZIP
PHONE (WILL BE USED ONLY IF WE HAVE A QUESTION) ()		CARD TYPE		CARD NUMBER	
EMAIL		<input type="checkbox"/> Visa <input type="checkbox"/> Am. Express <input type="checkbox"/> Master Card <input type="checkbox"/> Discover		EXPIRATION DATE (MM/YY)	
PURCHASE ORDER NUMBER			PURCHASE ORDER TERMS		
			SECURITY CODE		

PART NUMBER	SIZE/STYLE	QTY	PART NUMBER	SIZE/STYLE	QTY	PART NUMBER	SIZE/STYLE	QTY
6 lb. - Lime Green Pearl			10 lb. - Orange Pearl			13 lb. - Yellow Pearl		
60105544966	NO Drill	_____	60105544930	NO Drill	_____	60105544933	NO Drill	_____
60105544866	XXS-Drilled	_____	60105544630	S-Drilled	_____	60105544533	M-Drilled	_____
60105544766	XS-Drilled	_____	60105544530	M-Drilled	_____	60105544433	L-Drilled	_____
60105544666	S-Drilled	_____	60105544430	L-Drilled	_____	60105544333	XL-Drilled	_____
			60105544330	XL-Drilled	_____			
7 lb. - Fuchsia Pearl			11 lb. - Purple Pearl			14 lb. - Kelly Green Pearl		
60105544937	NO Drill	_____	60105544931	NO Drill	_____	60105544934	NO Drill	_____
60105544737	XS-Drilled	_____	60105544531	M-Drilled	_____	60105544534	M-Drilled	_____
60105544637	S-Drilled	_____	60105544431	L-Drilled	_____	60105544434	L-Drilled	_____
			60105544331	XL-Drilled	_____	60105544334	XL-Drilled	_____
						60105544234	XXL-Drilled	_____
8 lb. - Sky Blue Pearl			12 lb. - Red Pearl			15 lb. - Dark Blue Pearl		
60105544938	NO Drill	_____	60105544932	NO Drill	_____	60105544935	NO Drill	_____
60105544638	S-Drilled	_____	60105544632	S-Drilled	_____	60105544435	L-Drilled	_____
60105544538	M-Drilled	_____	60105544532	M-Drilled	_____	60105544335	XL-Drilled	_____
60105544438	L-Drilled	_____	60105544432	L-Drilled	_____	60105544235	XXL-Drilled	_____
9 lb. - Violet Pearl			60105544332	XL-Drilled	_____			
60105544939	NO Drill	_____	60105544232	XXL-Drilled	_____			
60105544639	S-Drilled	_____						
60105544539	M-Drilled	_____						
60105544439	L-Drilled	_____						

PRICE _____

Note: All drilled balls will be engraved with the ball grip size.

MY FIT BALL™	QTY
R8010059000 - (Fitting Ball and Display Stand)	_____

Please Fax this order to: 231-725-4429
or email it to: bcss.orders@brunbowl.com



BILLIARDS HOUSE BALL ORDER FORM

BILL TO (if a credit card sale, card holder's address is required)

SHIP TO (if different from bill to)

1113-09

CUSTOMER NUMBER			CUSTOMER NUMBER		
CONTACT			CONTACT		
BOWLING CENTER			BOWLING CENTER		
STREET			STREET		
CITY	STATE	ZIP	CITY	STATE	ZIP
PHONE (WILL BE USED ONLY IF WE HAVE A QUESTION) ()		CARD TYPE		CARD NUMBER	
EMAIL		<input type="checkbox"/> Visa <input type="checkbox"/> Am. Express <input type="checkbox"/> Master Card <input type="checkbox"/> Discover		EXPIRATION DATE (MM/YY)	
PURCHASE ORDER NUMBER		PURCHASE ORDER TERMS			
SECURITY CODE					

PART NUMBER	SIZE/STYLE	QTY	PART NUMBER	SIZE/STYLE	QTY	PART NUMBER	SIZE/STYLE	QTY
6 lb. - #6 Solid			10 lb. - #10 Striped			13 lb. - #13 Striped		
60105507966	NO Drill	_____	60105507930	NO Drill	_____	60105507933	NO Drill	_____
60105507866	XXS-Drilled	_____	60105507630	S-Drilled	_____	60105507533	M-Drilled	_____
60105507766	XS-Drilled	_____	60105507530	M-Drilled	_____	60105507433	L-Drilled	_____
60105507666	S-Drilled	_____	60105507430	L-Drilled	_____	60105507233	XL-Drilled	_____
			60105507230	XL-Drilled	_____			
7 lb. - #7 Solid			11 lb. - #11 Striped			14 lb. - #14 Striped		
60105507937	NO Drill	_____	60105507931	NO Drill	_____	60105507934	NO Drill	_____
60105507737	XS-Drilled	_____	60105507531	M-Drilled	_____	60105507534	M-Drilled	_____
60105507637	S-Drilled	_____	60105507431	L-Drilled	_____	60105507434	L-Drilled	_____
			60105507231	XL-Drilled	_____	60105507234	XL-Drilled	_____
						60105507134	XXL-Drilled	_____
8 lb. - #8 Solid			12 lb. - #12 Striped			15 lb. - #15 Striped		
60105507938	NO Drill	_____	60105507932	NO Drill	_____	60105507935	NO Drill	_____
60105507638	S-Drilled	_____	60105507632	S-Drilled	_____	60105507435	L-Drilled	_____
60105507538	M-Drilled	_____	60105507532	M-Drilled	_____	60105507235	XL-Drilled	_____
60105507438	L-Drilled	_____	60105507432	L-Drilled	_____	60105507135	XXL-Drilled	_____
9 lb. - #9 Striped			60105507232	XL-Drilled	_____			
60105507939	NO Drill	_____	60105507132	XXL-Drilled	_____			
60105507639	S-Drilled	_____						
60105507539	M-Drilled	_____						
60105507439	L-Drilled	_____						

PRICE _____

MY FIT BALL™	QTY
R8010059000 - (Fitting Ball and Display Stand)	_____

Please Fax this order to: 231-725-4429
or email it to: bcss.orders@brunbowl.com



FLASH HOUSE BALL ORDER FORM

BILL TO (if a credit card sale, cardholder's address is required)

SHIP TO (if different from bill to)

CUSTOMER NUMBER			CUSTOMER NUMBER		
CONTACT			CONTACT		
BOWLING CENTER			BOWLING CENTER		
STREET			STREET		
CITY	STATE	ZIP	CITY	STATE	ZIP
PHONE (WILL BE USED ONLY IF WE HAVE A QUESTION) ()		CARD TYPE		CARD NUMBER	
EMAIL		<input type="checkbox"/> Visa	<input type="checkbox"/> Am. Express	EXPIRATION DATE (MM/YY)	
		<input type="checkbox"/> MasterCard	<input type="checkbox"/> Discover	SECURITY CODE	
PURCHASE ORDER NUMBER			PURCHASE ORDER TERMS		

PART #	SIZE	QTY	PART #	SIZE	QTY	PART #	SIZE	QTY
8 LB LIME GREEN PEARL			12 LB ORANGE			14 LB KELLY EMERALD GREEN PEARL		
60105986938	NO DRILL		60105986932	NO DRILL		60105986934	NO DRILL	
60105986638	S DRILLED		60105986632	S DRILLED		60105986534	M DRILLED	
60105986538	M DRILLED		60105986532	M DRILLED		60105986434	L DRILLED	
60105986438	L DRILLED		60105986432	L DRILLED		60105986334	XL DRILLED	
10 LB PEARLESSECE			60105986332	XL DRILLED		60105986234	XXL DRILLED	
60105986930	NO DRILL		60105986232	XXL DRILLED		MY FIT BALL™		
60105986630	S DRILLED					R8010059000	FITTING BALL and DISPLAY STAND	
60105986530	M DRILLED							
60105986430	L DRILLED							
60105986330	XL DRILLED							

PRICE _____

 Fax this order to: 231•725•4429
 or email it to: bcss.orders@brunbowl.com

BILL TO (if a credit card sale, cardholder's address is required)				SHIP TO (if different from bill to)			
CUSTOMER NUMBER				CUSTOMER NUMBER			
CONTACT				CONTACT			
BOWLING CENTER				BOWLING CENTER			
STREET				STREET			
CITY		STATE	ZIP	CITY		STATE	ZIP
PHONE (WILL BE USED ONLY IF WE HAVE A QUESTION) ()			CARD TYPE		CARD NUMBER		
EMAIL			<input type="checkbox"/> Visa <input type="checkbox"/> Am. Express		EXPIRATION DATE (MM/YY)		SECURITY CODE
			<input type="checkbox"/> MasterCard <input type="checkbox"/> Discover				
PURCHASE ORDER NUMBER				TERMS		FREIGHT TERMS	

3 TIER CART		
PART #	COLOR	QTY
62860312000	BLACK	
62860312001	GREEN	
62860312002	YELLOW	
62860312003	BLUE	
62860312004	SILVER	
PRICE		_____

2 TIER CART		
PART #	COLOR	QTY
62860311000	BLACK	
62860311001	GREEN	
62860311002	YELLOW	
62860311003	BLUE	
62860311004	SILVER	
PRICE		_____

BALL RAMP		
PART #	COLOR	QTY
62860310000	BLACK	
62860310001	GREEN	
62860310002	YELLOW	
62860310003	BLUE	
62860310004	SILVER	
PRICE		_____



Fax this order to: 231•725•4429
or email it to: bcss.orders@brunbowl.com

BILL TO (if a credit card sale, cardholder's address is required)				SHIP TO (if different from bill to)			
CUSTOMER NUMBER				CUSTOMER NUMBER			
CONTACT				CONTACT			
BOWLING CENTER				BOWLING CENTER			
STREET				STREET			
CITY		STATE	ZIP	CITY		STATE	ZIP
PHONE (WILL BE USED ONLY IF WE HAVE A QUESTION) ()		CARD TYPE		CARD NUMBER			
EMAIL		<input type="checkbox"/> Visa <input type="checkbox"/> Am. Express <input type="checkbox"/> MasterCard <input type="checkbox"/> Discover		EXPIRATION DATE (MM/YY)		SECURITY CODE	
PURCHASE ORDER NUMBER				TERMS		FREIGHT TERMS	

PREMIUM LACE		
PART #	SIZE	QTY
58109114001	MAN1/WOMAN2.5/EUR31	
58109114115	MAN1.5/WOMAN3/EUR32	
58109114002	MAN2/WOMAN3.5/EUR33	
58109114025	MAN2.5/WOMAN4	
58109114003	MAN3/WOMAN4.5/EUR34	
58109114035	MAN3.5/WOMAN5/EUR35	
58109114004	MAN4/WOMAN5.5	
58109114045	MAN4.5/WOMAN6/EUR36	
58109114005	MAN5/WOMAN6.5/EUR37	
58109114055	MAN5.5/WOMAN7	
58109114006	MAN6/WOMAN7.5/EUR38	
58109114065	MAN6.5/WOMAN8	
58109114007	MAN7/WOMAN8.5/EUR39	
58109114075	MAN7.5/WOMAN9/EUR40	
58109114008	MAN8/WOMAN9.5	
58109114085	MAN8.5/WOMAN10/EUR41	
58109114009	MAN9/WOMAN10.5/EUR42	
58109114095	MAN9.5/WOMAN11	
58109114010	MAN10/WOMAN11.5/EUR43	
58109114096	MAN10.5/WOMAN12/EUR44	
58109114011	MAN11/WOMAN12.5	
58109114097	MAN11.5/WOMAN13/EUR45	
58109114012	MAN12/EUR46	
58109114013	MAN13/EUR47	
58109114014	MAN14/EUR48	

PREMIUM LACE (continued)		
PART #	SIZE	QTY
58109114015	MAN15/EUR49	
58109114016	MAN16/EUR50	
58109114017	MAN17/EUR51	
58109114018	MAN18/EUR53	

PREMIUM HOOK & LOOP		
PART #	SIZE	QTY
58109116001	MAN1/WOMAN2.5/EUR31	
58109116115	MAN1.5/WOMAN3/EUR32	
58109116002	MAN2/WOMAN3.5/EUR33	
58109116025	MAN2.5/WOMAN4	
58109116003	MAN3/WOMAN4.5/EUR34	
58109116035	MAN3.5/WOMAN5/EUR35	
58109116004	MAN4/WOMAN5.5	
58109116045	MAN4.5/WOMAN6/EUR36	
58109116005	MAN5/WOMAN6.5/EUR37	
58109116055	MAN5.5/WOMAN7	
58109116006	MAN6/WOMAN7.5/EUR38	
58109116065	MAN6.5/WOMAN8	
58109116007	MAN7/WOMAN8.5/EUR39	
58109116075	MAN7.5/WOMAN9/EUR40	
58109116008	MAN8/WOMAN9.5	
58109116085	MAN8.5/WOMAN10/EUR41	
58109116009	MAN9/WOMAN10.5/EUR42	
58109116095	MAN9.5/WOMAN11	
58109116010	MAN10/WOMAN11.5/EUR43	

PREMIUM HOOK & LOOP (continued)		
PART #	SIZE	QTY
58109116096	MAN10.5/WOMAN12/EUR44	
58109116011	MAN11/WOMAN12.5	
58109116097	MAN11.5/WOMAN13/EUR45	
58109116012	MAN12/EUR46	
58109116013	MAN13/EUR47	
58109116014	MAN14/EUR48	
58109116015	MAN15/EUR49	
58109116016	MAN16/EUR50	
58109116017	MAN17/EUR51	
58109116018	MAN18/EUR53	

YOUTH		
PART #	SIZE	QTY
58109115007	YOUTH 7/EUR24	
58109115008	YOUTH 8/EUR25	
58109115009	YOUTH 9/EUR26	
58109115010	YOUTH 10/EUR27	
58109115011	YOUTH 11/EUR28	
58109115012	YOUTH 12/EUR29	
58109115013	YOUTH 13/EUR30	
58109115001	YOUTH 1/EUR31	
58109115002	YOUTH 2/EUR33	
58109115003	YOUTH 3/W5.5/EUR34	
58109115004	YOUTH M4/W5.5	

PRICE _____



Fax this order to: 231•725•4429
or email it to: bcss.orders@brunbowl.com



HYBRID LACE, HOOK AND LOOP, AND YOUTH RENTAL SHOES ORDER

BILL TO (if a credit card sale, cardholder's address is required)				SHIP TO (if different from bill to)			
CUSTOMER NUMBER				CUSTOMER NUMBER			
CONTACT				CONTACT			
BOWLING CENTER				BOWLING CENTER			
STREET				STREET			
CITY		STATE	ZIP	CITY		STATE	ZIP
PHONE (WILL BE USED ONLY IF WE HAVE A QUESTION) ()			CARD TYPE		CARD NUMBER		
EMAIL			<input type="checkbox"/> Visa <input type="checkbox"/> Am. Express <input type="checkbox"/> MasterCard <input type="checkbox"/> Discover		EXPIRATION DATE (MM/YY)		SECURITY CODE
			PURCHASE ORDER NUMBER		TERMS		FREIGHT TERMS

HYBRID LACE			HYBRID HOOK AND LOOP			HYBRID YOUTH HOOK AND LOOP		
PART #	SIZE	QTY	PART #	SIZE	QTY	PART #	SIZE	QTY
58109305035	MAN3.5/WOMAN5/EUR35		58109306035	MAN3.5/WOMAN5/EUR35		58109304005	YOUTH 5/EUR22	
58109305004	MAN4/WOMAN5.5		58109306004	MAN4/WOMAN5.5		58109304006	YOUTH 6/EUR23	
58109305045	MAN4.5/WOMAN6/EUR36		58109306045	MAN4.5/WOMAN6/EUR36		58109304007	YOUTH 7/EUR24	
58109305005	MAN5/WOMAN6.5/EUR37		58109306005	MAN5/WOMAN6.5/EUR37		58109304008	YOUTH 8/EUR25	
58109305055	MAN5.5/WOMAN7		58109306055	MAN5.5/WOMAN7		58109304009	YOUTH 9/EUR26	
58109305006	MAN6/WOMAN7.5/EUR38		58109306006	MAN6/WOMAN7.5/EUR38		58109304010	YOUTH 10/EUR27	
58109305065	MAN6.5/WOMAN8		58109306065	MAN6.5/WOMAN8		58109304011	YOUTH 11/EUR28	
58109305007	MAN7/WOMAN8.5/EUR39.5		58109306007	MAN7/WOMAN8.5/EURO39		58109304012	YOUTH 12/EUR29	
58109305075	MAN7.5/WOMAN9/EUR40		58109306075	MAN7.5/WOMAN9/EUR40		58109304013	YOUTH 13/EUR30	
58109305008	MAN8/WOMAN9.5		58109306008	MAN8/WOMAN9.5		58109304001	YOUTH 1/EUR31	
58109305085	MAN8.5/WOMAN10/EUR41		58109306085	MAN8.5/WOMAN10/EUR41		58109304015	YOUTH 1.5/EUR32	
58109305009	MAN9/WOMAN10.5/EUR42		58109306009	MAN9/WOMAN10.5/EUR42		58109304002	YOUTH 2/EUR33	
58109305095	MAN9.5/WOMAN11		58109306095	MAN9.5/WOMAN11		58109304003	YOUTH 3/W5.5/EUR34	
58109305010	MAN10/WOMAN11.5/EUR43		58109306010	MAN10/WOMAN11.5/EUR43		58109304004	YOUTH 4	
58109305096	MAN10.5/WOMAN12/EUR44		58109306096	MAN10.5/WOMAN12/EUR44				
58109305011	MAN11/WOMAN12.5		58109306011	MAN11/WOMAN12.5				
58109305097	MAN11.5/WOMAN 13/EUR45		58109306097	MAN11.5/WOMAN13/EUR45				
58109305012	MAN12/EUR46		58109306012	MAN12/EUR46				
58109305013	MAN13/EUR47		58109306013	MAN13/EUR47				
58109305014	MAN14/EUR48		58109306014	MAN14/EUR48				
58109305015	MAN15/EUR49		58109306015	MAN15/EUR49				
58109305016	MAN16/EUR50		58109306016	MAN16/EUR50				

PRICE _____



Fax this order to: 231•725•4429
or email it to: bcss.orders@brunbowl.com

BILL TO (if a credit card sale, cardholder's address is required)

SHIP TO (if different from bill to)

CUSTOMER NUMBER			CUSTOMER NUMBER		
CONTACT			CONTACT		
BOWLING CENTER			BOWLING CENTER		
STREET			STREET		
CITY	STATE	ZIP	CITY	STATE	ZIP
PHONE (WILL BE USED ONLY IF WE HAVE A QUESTION) ()	CARD TYPE		CARD NUMBER		
EMAIL	<input type="checkbox"/> Visa	<input type="checkbox"/> Am. Express	EXPIRATION DATE (MM/YY)		SECURITY CODE
	<input type="checkbox"/> MasterCard	<input type="checkbox"/> Discover			
PURCHASE ORDER NUMBER			TERMS		FREIGHT TERMS

VALUE SPORT ADULT LACE			VALUE SPORT ADULT LACE (continued)			VALUE SPORT YOUTH LACE		
PART #	SIZE	QTY	PART #	SIZE	QTY	PART #	SIZE	QTY
58109303004	MAN4/WOMAN5.5		58109303096	MAN10.5/WOMAN12/EUR44		58109302007	YOUTH VALUE 7/EUR24	
58109303045	MAN4.5/WOMAN6/EUR36		58109303011	MAN11/WOMAN12.5		58109302008	YOUTH VALUE 8/EUR25	
58109303005	MAN5/WOMAN6.5/EUR37		58109303097	MAN11.5/WOMAN13/EUR45		58109302009	YOUTH VALUE 9/EUR26	
58109303055	MAN5.5/WOMAN7		58109303012	MAN12/EUR46		58109302010	YOUTH VALUE 10/EUR27	
58109303006	MAN6/WOMAN7.5/EUR38.5		58109303013	MAN13/EUR47		58109302011	YOUTH VALUE 11/EUR28	
58109303065	MAN6.5/WOMAN8		58109303014	MAN14/EUR48		58109302012	YOUTH VALUE 12/EUR29	
58109303007	MAN7/WOMAN8.5/39.5		58109303015	MAN15/EUR49		58109302013	YOUTH VALUE 13/EUR30	
58109303075	MAN7.5/WOMAN9/EUR40		58109303016	MAN16/EUR50		58109302001	YOUTH VALUE 1/EUR31	
58109303008	MAN8/WOMAN9.5/EUR40.5					58109302015	YOUTH VALUE 1.5/EUR32	
58109303085	MAN8.5/WOMAN10/EUR41					58109302002	YOUTH VALUE 2/EUR33	
58109303009	MAN9/WOMAN10.5/EUR42					58109302025	YOUTH VALUE 2.5	
58109303095	MAN9.5/WOMAN11					58109302003	YOUTH VALUE 3/W5.5/EUR34	
58109303010	MAN10/WOMAN11.5/EUR43					58109302035	YOUTH VALUE 3.5/EUR35	

PRICE _____



Fax this order to: 231•725•4429
or email it to: bcss.orders@brunbowl.com

BILL TO (if a credit card sale, cardholder's address is required)

SHIP TO (if different from bill to)

CUSTOMER NUMBER			CUSTOMER NUMBER		
CONTACT			CONTACT		
BOWLING CENTER			BOWLING CENTER		
STREET			STREET		
CITY	STATE	ZIP	CITY	STATE	ZIP
PHONE (WILL BE USED ONLY IF WE HAVE A QUESTION) ()		CARD TYPE		CARD NUMBER	
EMAIL		<input type="checkbox"/> Visa <input type="checkbox"/> Am. Express <input type="checkbox"/> MasterCard <input type="checkbox"/> Discover		EXPIRATION DATE (MM/YY)	
PURCHASE ORDER NUMBER			TERMS		FREIGHT TERMS

MAX PINS

PART #	DESCRIPTION	QTY	PRICE
63861165167	MAX CROWN GRAPHIC GLOW SET		
63861166167	MAX STRIPE GRAPHIC GLOW SET		
63861167167	MAX RED CROWN SET		
63861168167	MAX RED STRIPE SET		

SCORE KING PINS

PART #	DESCRIPTION	QTY	PRICE
63861180167	SCORE KING GLOW CROWN SET		
63861182167	SCORE KING GLOW STRIP SET		
63861179167	SCORE KING RED CROWN SET		
63861181167	SCORE KING RED STRIPE SET		

NOVELTY PINS

PART #	DESCRIPTION	QTY	PRICE
62861092167	HAPPY BIRTHDAY PIN SET		
62861092000	HAPPY BIRTHDAY PIN SINGLE		
63861157167	TROPHY PIN SET		
63861157000	TROPHY PIN SINGLE		
63861161167	MAGENTA COLORED PIN SET		
63861161000	MAGENTA COLORED PIN SINGLE		
63861137167	GREEN COLORED PIN SET		
63861137000	GREEN COLORED PIN SINGLE		
63861138167	YELLOW COLORED PIN SET		
63861138000	YELLOW COLORED PIN SINGLE		
63861139167	ORANGE COLORED PIN SET		
63861139000	ORANGE COLORED PIN SINGLE		

PRICE _____



Fax this order to: 231•725•4429
or email it to: bcss.orders@brunbowl.com

Brunswick®

525 West Laketon Avenue
Muskegon, MI 49441-2601 USA
1-800-Yes-Bowl (Options 2,2,*)
1-231-725-4966 (Options 2,2,*)
inquiries@brunswickbowling.com
www.brunswickbowling.com

Go to www.brunswickbowling.com/contact to find a local Brunswick Sales Representative

Kegel is a registered trademark of KEGEL, LLC. Surlyn is a registered trademark of E.I. du Pont de Nemours and Company. USBC is a registered trademark of United States Bowling Congress, Inc. Windows is a registered trademark of Microsoft Corporation in the United States and/or other countries. IBM is a registered trademark of International Business Machines Corporation. All other trademarks belong to Brunswick Bowling Products, LLC.

Brunswick is committed to continuous improvement. As a result, all specifications and options are subject to change without notice. Not for reproduction without the express written consent of Brunswick Bowling Products, LLC.

©2021 Brunswick Bowling Products, LLC. Printed in the USA. • Item #10-095400-002 • Form #0621-48

2021-2022 CATALOG